



# **Varuwan Vadivelan Institute of Technology**

**Dharmapuri – 636 703**

---

## **LAB MANUAL**

**Regulation : 2013**

**Branch : B.E. – ECE**

**Year & Semester : IV Year / VII Semester**

**EC6712- OPTICAL AND MICROWAVE LABORATORY**

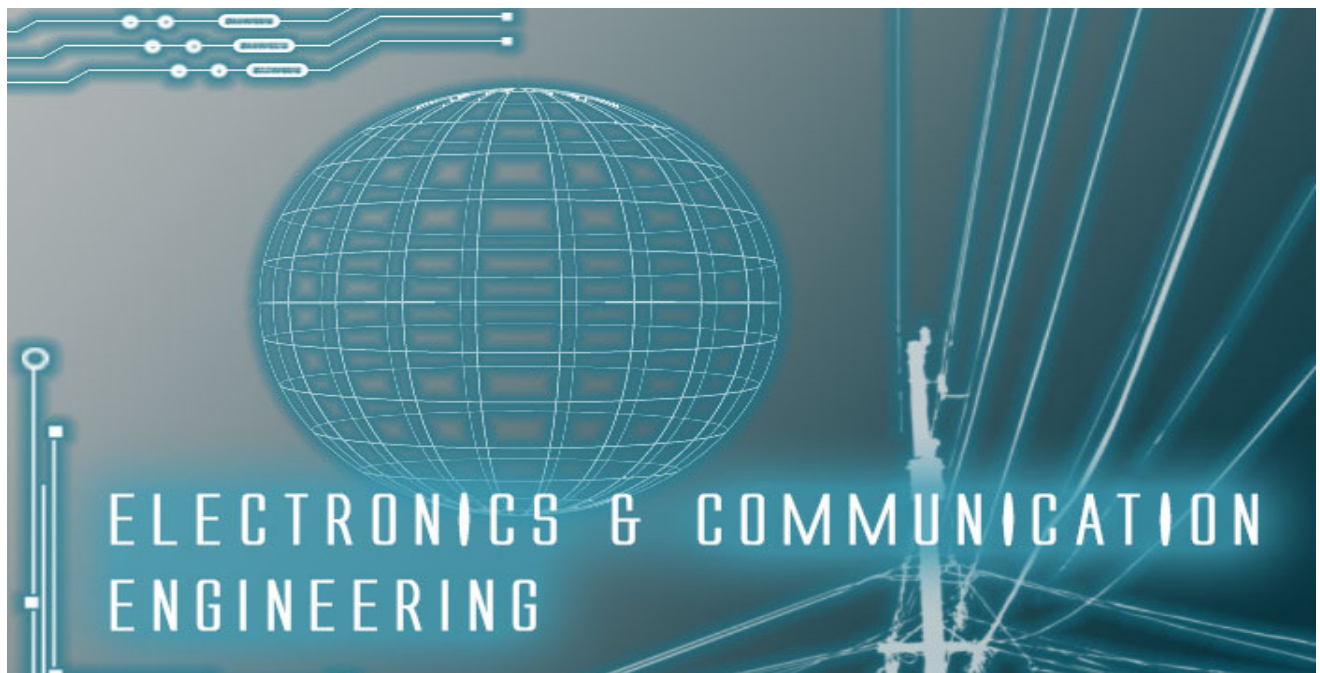

# **ANNA UNIVERSITY: CHENNAI**

## **SYLLABUS R - 2013**

L T P C  
0 0 3 2

### **LIST OF EXPERIMENTS**

#### **OPTICAL EXPERIMENTS**

1. DC Characteristics of LED and PIN Photo diode
2. Mode Characteristics of Fibers
3. Measurement of connector and bending losses
4. Fiber optic Analog and Digital Link- frequency response(analog) and eye diagram (digital)
5. Numerical Aperture determination for Fibers
6. Attenuation Measurement in Fibers

#### **MICROWAVE EXPERIMENTS**

1. Reflex klystron or Gunn diode characteristics and basic microwave parameter measurement such as VSWR, frequency, wavelength.
2. Directional Coupler Characteristics.
3. Radiation Pattern of Horn Antenna.
4. S-parameter Measurement of the following microwave components (Isolator, Circulator, E plane Tee, H Plane Tee, Magic Tee)
5. Attenuation and Power Measurement

**TOTAL: 45 PERIODS**

## INDEX

EX.NO	DATE	LIST OF EXPERIMENTS	STAFF SIGNATURE	REMARKS
1		DC Characteristics of LED		
2		Mode Characteristics of Fibers		
3		Measurement of Connector And Bending Losses		
4.a)		Setting Up OF Analog Optical Link		
4.b)		Setting Up of Digital Optical Link		
5		Eye Pattern Measurement Using A High Bandwidth Oscilloscope		
6		Numerical Aperture Determination For Fibers		
7		Attenuation Measurement		
8		V-I Characteristics of Gunn Oscillator		
9		Mode Characteristics Of Reflex Klystron		
10		Wavelength & Frequency Measurement		
11		VSWR Measurements		
12		Attenuation Measurement		
13		Directional Coupler		
14		Isolator And Circulator – S - Parameter Measurement		
15		S - Matrix Characterization of E-Plane T ,H-Plane T and Magic Tee.		
16		Radiation Pattern Of Horn Antenna		

## INTRODUCTION

### OPTICAL AND MICROWAVE LABORATORY

#### **RECTANGULAR WAVE GUIDE**

Wave guides are manufactured to the highest mechanical and electrical standards and mechanical tolerances.

L and S band wave guides are fabricated by precision brazing of brass-plates and all other wave guides are in extrusion quality.

W.G. sections of specified length can be supplied with flanges, painted outside and silver or gold plated inside.

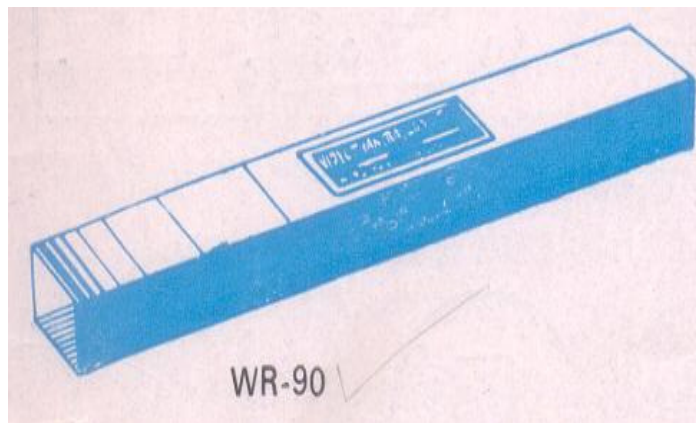

#### **SPECIFICATIONS X Band**

EIA No. : WR - 90

Frequency : 8.2 - 12.4 GHZ

Width : 2.286cm      Height : 1.1016cm      Width : 2.54 cm

Height : 1.27cm       $\pm$  Tol. ( $\mu$ m) : 7.6      Material : Brass/Copper.

#### **FIXED ATTENUATORS**

Series 5000 fixed Attenuators are meant for inserting a known attenuation in a wave guide system. These consists of a lossy vane inserted in a section of wave guide, flanged on both ends. These are useful for isolation of wave guide circuits, padding and extending the range of measuring equipments.

3Fixed Attenuators are available for 3,6 or 10 dB attenuation values, but any attenuation value between 0 and 30dB can be provided.

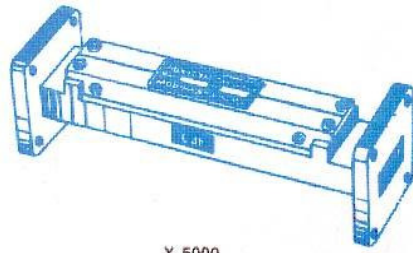

X-5000

## SPECIFICATIONS

Model No: X-5000 /Frequency : 8.12 - 12.4 GHZ /Attenuation (dB) : 3,6,10/Calibration Accuracy :  $\pm 0.2$ dB/Avg Power : 2W/Max VSWR : 1.10/Max Insertion Loss (dB) : 0.2/W.G. Type: WG – 90/Flange Type (UG/U) : 39.

A precision built probe carriage has a centimeter scale with a vernier reading of 0.1mm least count and a dial gauge can be mounted easily if precise readings are required.

Model No.	: X - 6051
Freq (Ghz)	: 8.2 - 12.4
Max Residual VSWR :	1.01
WG type (WR-)	: 90
Flange Type (UG-/U) :	39

## TUNABLE PROBE

Model 6055 Tunable probe is designed for use with model 6051 slotted sections. These are meant for exploring the energy of the EF in a suitably fabricated section of wave guide.

The depth of penetration into a wave guide - section is adjustable by the knob of the probe. The tip pick up the RF power from the line and this power is rectified by crystal detector, which is then fed to the VSWR meter or indicating instrument.

Model No. : X6055 /Freq (Ghz) : 8.2 - 12.4 /output Connector : BNC(F) /Detector : IN23.

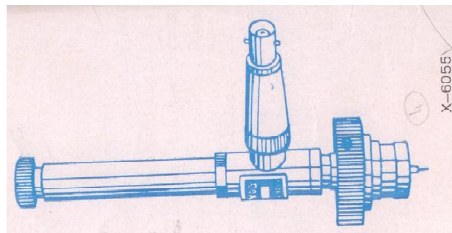

## WAVE GUIDE DETECTOR MOUNT (TUNABLE)

Model 4051 Tunable Detector Mount is simple and easy to use instrument for detecting microwave power through a suitable detector. It consists of a detector crystal mounted in a section of a Wave guide and shorting plunger for matching purpose. The output from the crystal may be fed to an indicating instrument. In K and R bands detector mounts the plunger is driven by a micrometer.

Model No.	: X - 4051
Freq. Range (Ghz)	: 8.2 - 12.4
O/P Connector	: BNC (F)
Wave guide type (WR-)	: 90
Flange Type (UG/U)	: 39
Detector	: IN23

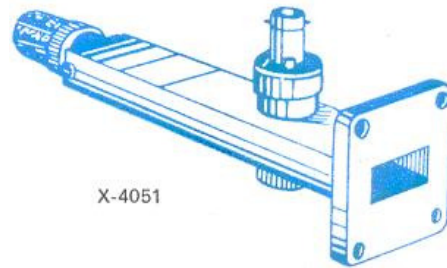

## KLYSTRON MOUNT

Model 2051 Klystron mounts are meant for mounting corresponding Klystrons such as 2K25, 723A/B, 726A or RK - 5976 etc.

These consists of a section of wave guide flanged on one end and terminated with a movable short on the other end. An octal base with cable is provided for Klystron.

Model No. :	X – 2051/ Freq. Range (GHz) 8.2 - 12.4/ WG Type (WR-) : 90
Flange Type (UG-/U):	39

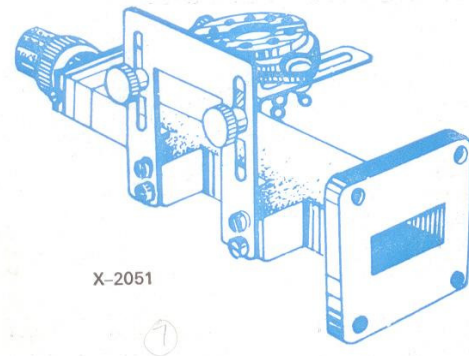

## CIRCULATORS

Model 6021 and 6022 are T and Y types of three port circulators respectively. These are precisely machined and assembled to get the desired specifications. Circulators are matched three port devices and these are meant for allowing Microwave energy to flow in clockwise direction with negligible loss but almost no transmission in the anti-clockwise direction.

Model No.	: X – 6021
Frequency Range (Ghz)	: 8.6 - 10.6 or 10.2 - 12.2
Min. Isolation (dB)	: 20
Max. Insertion Loss (dB) :	0.4
Max. VSWR	: 1.20



## WAVE GUIDE DETECTOR MOUNT (TUNABLE)

Model 4051 Tunable Detector Mount is simple and easy to use instrument for detecting microwave power through a suitable detector. It consists of a detector crystal mounted in a section of a Wave guide and shorting plunger for matching purpose. The output from the crystal may be fed to an indicating instrument. In K and R bands detector mounts the plunger is driven by a micrometer.

Model No.	: X - 4051
Freq. Range (Ghz)	: 8.2 - 12.4
O/P Connector	: BNC (F)
Wave guide type (WR-)	: 90
Flange Type (UG/U)	: 39
Detector	: IN23

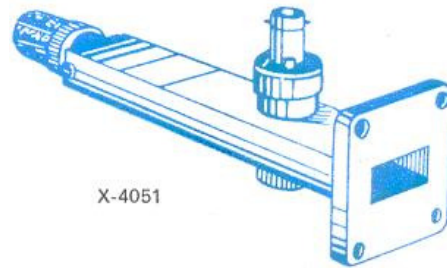

## KLYSTRON MOUNT

Model 2051 Klystron mounts are meant for mounting corresponding Klystrons such as 2K25, 723A/B, 726A or RK - 5976 etc.

These consists of a section of wave guide flanged on one end and terminated with a movable short on the other end. An octal base with cable is provided for Klystron.

Model No. :	X – 2051/ Freq. Range (GHz) 8.2 - 12.4/ WG Type (WR-) : 90
Flange Type (UG-/U):	39

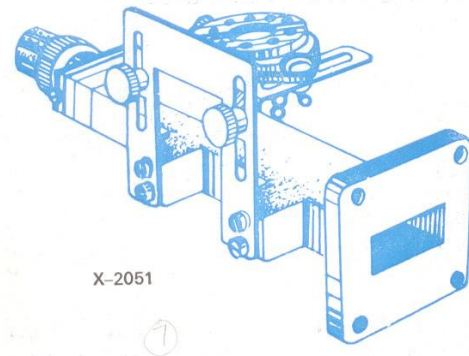

## CIRCULATORS

Model 6021 and 6022 are T and Y types of three port circulators respectively. These are precisely machined and assembled to get the desired specifications. Circulators are matched three port devices and these are meant for allowing Microwave energy to flow in clockwise direction with negligible loss but almost no transmission in the anti-clockwise direction.

Model No.	: X – 6021
Frequency Range (Ghz)	: 8.6 - 10.6 or 10.2 - 12.2
Min. Isolation (dB)	: 20
Max. Insertion Loss (dB) :	0.4
Max. VSWR	: 1.20





## SLIDE SCREW TUNERS

Model 4041 slide screw tuners are used for matching purposes by changing the penetration and position of a screw in the slot provided in the centre of the wave guide.

These consists of a section of wave guide flanged on both ends and a thin slot is provided in the broad wall of the Wave guide. A carriage carrying the screw, is provided over the slot. A VSWR upto 20 can be tuned to a value less than 1.02 at certain frequency.

Model No. : X - 4041/ Freq. Range (Ghz) : 8.2 - 12.4/WG Type (WR-) : 90  
Flange type (UG/U) : 39

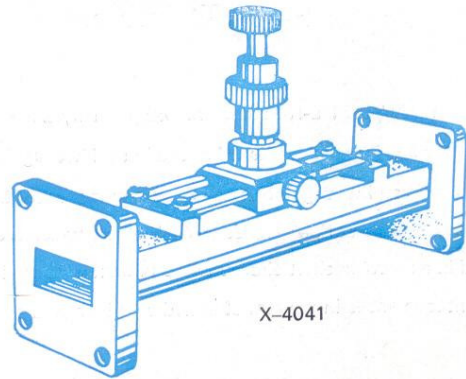

## MULTIHOLE DIRECTIONAL COUPLERS

Model 6000 series Multihole directional couplers are useful for sampling a part of Microwave energy for monitoring purposes and for measuring reflections and impedance. These consists of a section of Wave guide with addition of a second parallel section of wave guide thus making it a four port network. However the fourth port is terminated with a matched load. These two parallel sections are coupled to each other through many holes, almost to give uniform coupling; minimum frequency sensitivity and high directivity. These are available in 3,6,10,20 and 40dB coupling.

Model No. : X - 6003  
Frequency Range (Ghz) : 8.2 - 12.4  
Coupling (dB) : 3,10,20,40  
Directivity (dB) : 35  
Wave guide type (WR-) : 90  
Flange type (UG/U) : 39



## E PLANE TEE

Model 3061 E - plane tee are series type T - junction and consists of three section of wave guide joined together in order to divide or compare power levels. The signal entering the first port of this T - junction will be equally dividing at second and third ports of the same magnitude but in opp. phase

Model No. : X - 3061  
Frequency Range (Ghz) : 8.2 - 12.4  
WG Type (WR-) : 90  
Flange Type (UG/U) : 39

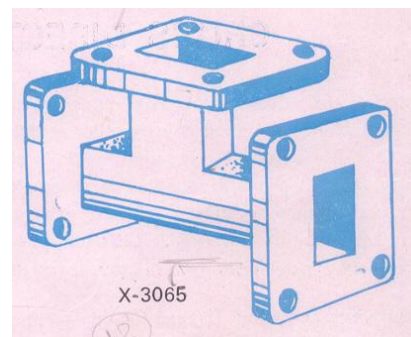



## H - PLANT TEE

Model 3065 H - Plane Tee are shunt type T - junction for use in conjunction with VSWR meters, frequency - meters and other detector devices. Like in E-plane tee, the signal fed through first port of H - plane Tee will be equally divided in magnitude at second and third ports but in same phase.

Model No. : X - 3065  
Frequency Range (GHz) : 8.2 - 12.4  
WG Type (WR-) : 90  
Flange Type (UG-/U) : 39

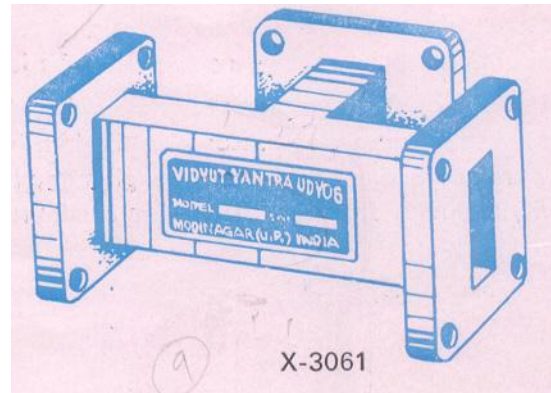

## MAGIC TEE

Model 3045 E - H Tee consists of a section of wave guide in both series and shunt wave guide arms, mounted at the exact midpoint of main arm. Both ends of the section of wave guide and both arms are flanged on their ends. These Tees are employed in balanced mixers, AFC circuits and impedance measurement circuits etc. This becomes a four terminal device where one terminal is isolated from the input terminal.

Model No. : X - 3045  
Frequency Range (Ghz) : 8.2 - 12.4  
WG Type (WR-) : 90  
Flange Type (UR-/U) : 39

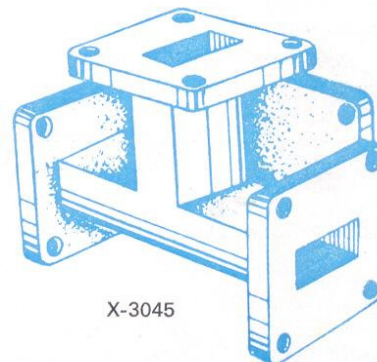

## MOVABLE SHORT

Model 4081 movable shorts consists of a section waveguide, flanged on one end and terminated with a movable shorting plunger on the other end. By means of this noncontacting type plunger, a reflection co-efficient of almost unity may be obtained.

Model No. : X - 4081  
Frequency Range (GHz) : 8.2 - 12.4  
WG Type (WR-) : 90  
Flange Type (UG-/U) : 39

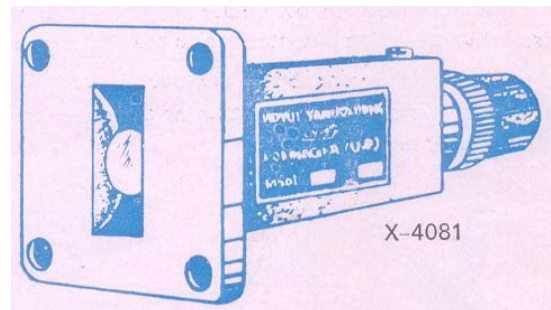

## MATCHED TERMINATION

Model 4000 are low power and non-reflective type of terminations. It consists of a small and highly dissipative taper flap mounted inside the centre of a section of wave guide. Matched Terminations are useful for USWR measurement of various waveguide components. These are also employed as dummy and as a precise reference loads with Tee junctions, directional couplers and other similar dividing devices.

Model No. : X - 4000, Freq. Range (Ghz) :  
8.2 - 12.4 Max VSWR : 1.04  
AV Power : 2W, WG Type (WR-) 90,  
Flange Type (UG-/U) : 39

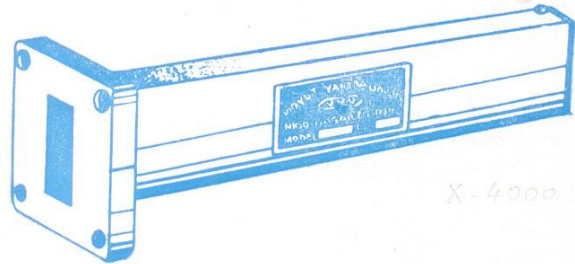

## PYRAMIDAL WAVEGUIDE HORN ANTENNA

Model 5041 pyramidal Wave guide Horn antenna consists of waveguide joined to pyramidal section fabricated from brass sheet. The pyramidal section shapes the energy to concentrate in a specified beam. Wave guide horns are used as feed horns as radiators for reflectors and lenses and as a pickup antenna for receiving microwave power.

Model No. : X - 5041  
Frequency Range (Ghz) : 8.2 - 12.4  
Max VSWR : 1.20  
WG Type (WR-) : 90  
Flange Type (UG-/U) : 39

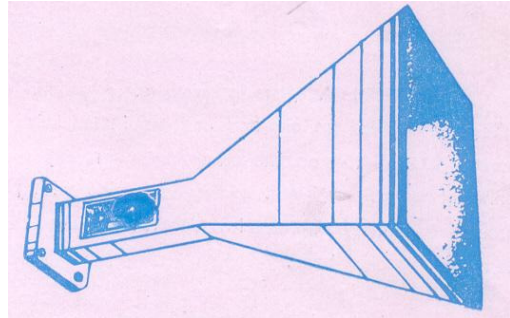

## GUNN OSCILLATORS

Model 2151 Gunn Oscillators are solid state microwave energy generators. These consists of waveguide cavity flanged on one end and micrometer driven plunger fitted on the other end. A gunn-diode is mounted inside the Wave guide with BNC (F) connector for DC bias. Each Gunn oscillators is supplied with calibration certificate giving frequency vs micrometer reading.

Model No. : X - 2152, Freq : 8.2 - 12.4 Ghz,  
Min output power : 10 MW  
WG Type (WR-) : 90 Flange Type (UG-/U) : 39

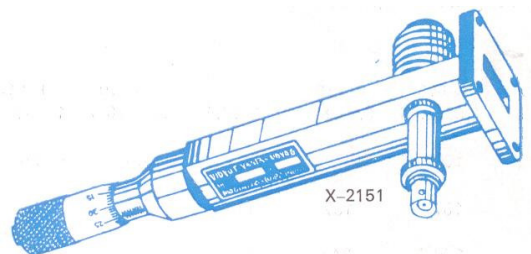

## PIN MODULATORS

Model 451 pin modulators are designed to modulate the cw output of Gunn Oscillators. It is operated by the square pulses derived from the UHF(F) connector of the Gunn power supply. These consists of a pin diode mounted inside a section of Wave guide flanged on it's both end. A fixed attenuation vane is mounted inside at the input to protect the oscillator.

Model No.	: X - 451
Frequency Range (Ghz)	: 8.3 - 12.4
Max RF Power	: 1W
WG Type (WR-)	: 90
Flange Type (GHz)	: 39

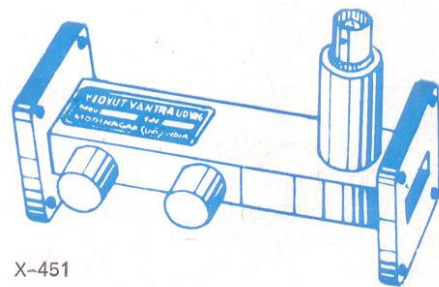

## GUNN POWER SUPPLY

Model X-110 Gunn Power supply comprises of an regulated DC power supply and a square wave generator, designed to operate Gunn-Oscillator model 2151 or 2152, and pin modulators model 451 respectively. The DC voltage is variable from 0 - 10V. The front panel meter monitors the gunn voltage and the current drawn by the Gunn diode. The square wave of generator is variable from 0 - 10V. in amplitude and 900 - 1100 Hz in frequency. The power supply has been so designed to protect Gunn diode from reverse voltage application over transient and low frequency oscillations by the negative resistance of the Gunn-diode.

## SPECIFICATIONS

Amplifier Type	:	High gain tuned at one frequency
Frequency	:	1000 Hz $\pm$ 2%
Sensitivity	:	0.1 microvolt at 200 for full scale
Band width	:	25 - 30 cps
Range	:	70dB min in 10 dB steps
Scale selector	:	Normal Expand
Gain control	:	'Coarse' & 'Fine'
Mains power	:	230V, 50Hz

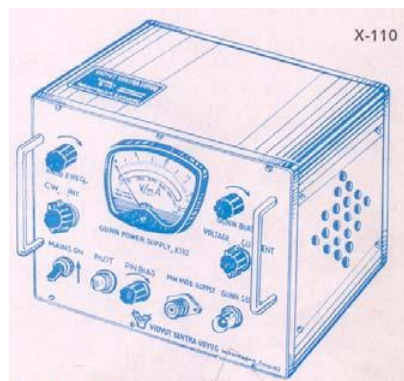

## **ISOLATORS**

The three port circulators Model 6021 may be converted into isolators by terminating one of its port into matched load. these will work over the frequency range of circulators. These are well matched devices offering low forward insertion loss and high reverse isolation.

Model No.	: X – 6022
Frequency Range (GHz)	: 8.6 - 10.6 or 10.2 - 12.2
Min Isolation (dB)	: 20
Max Insertion Loss (dB)	: 0.4
Max VSWR	: 1.20

EX.NO:1

DATE:

## DC CHARACTERISTICS OF LED

### AIM

To study the V-I and P-I characteristics of LED.

### EQUIPMENTS REQUIRED

1. VOFT-07A Trainer - 01
2. Digital multimeter - 02
3. Power meter(optional)- 01

### PROCEDURE

1. Construct the equipment as shown in above figure.
2. Switch ON the power supply using IR switch.
3. Set the SPDT switch (Source switch) in OFF position.
4. Turn the POT 1 to minimum level.
5. Now measure the diode series resistance at P1 and P3 (Terminal protective resistance -  $660\Omega$ ).  
Diode series resistance  $R = \text{Total resistance} - 660\Omega$
6. Switch ON the SPDT switch and measure series voltage across resistor ( $V_R$ ) at P1 and P3.
7. Calculate the diode current  $I = V_R/R$
8. Measure the voltage across diode.
9. Now step by step vary the POT 1 minimum level to maximum level and note down the corresponding readings.
10. Now plot the graph for voltage across diode  $V_D$  Vs current.

**CIRCUIT DIAGRAM**

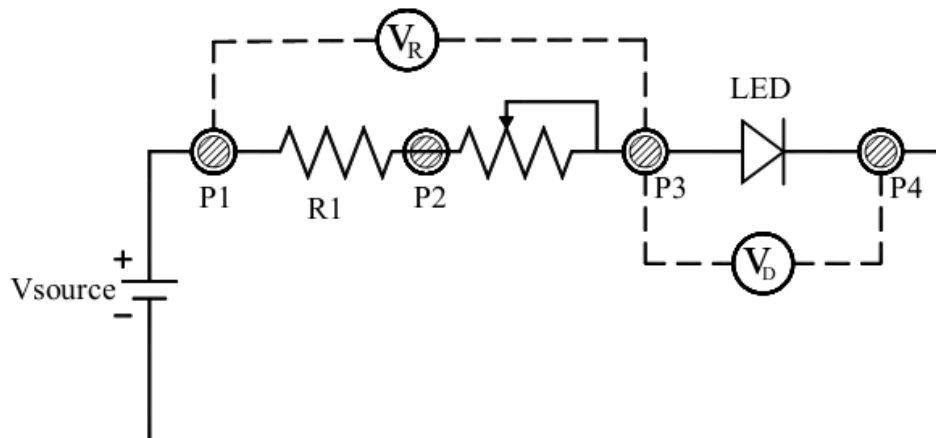

**V-I Characteristics of LED**

**TABULATION:** Input Voltage = +5V

S.NO.	Voltage across Resistor (VR)	Series resistance ( R )	Voltage across Diode (VD)	Current through diode (mA)

**MODEL GRAPH.**

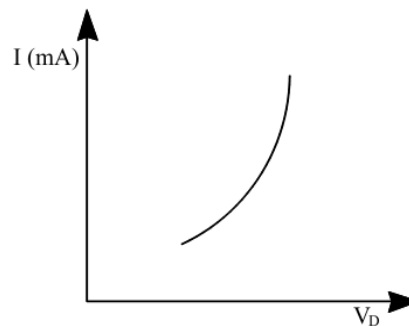

**CIRCUIT DIAGRAM**

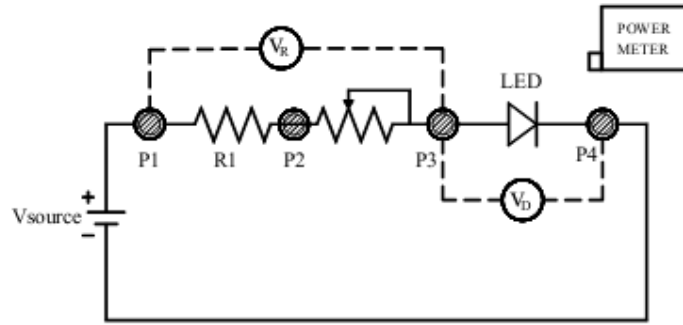

P-I Characteristics of LED

**TABULATION:** Input Voltage = +5V

S.NO.	Voltage across Resistor (VR)	Series resistance ( R )	Current through diode (mA)	Power (mW)

**MODEL GRAPH**

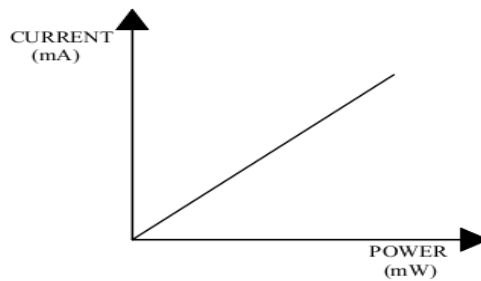



## PROCEDURE

1. Construct the equipment as shown in above figure.
2. Switch ON the power supply using IR switch.
3. Set the SPDT switch (Source switch) in OFF position.
4. Turn the POT 1 to minimum level.
5. Now measure the diode series resistance at P1 and P3 (Terminal protective resistance -  $660\Omega$ ).

$$\text{Diode series resistance } R = \text{Total resistance} - 660\Omega$$

6. Switch ON the SPDT switch and measure series voltage across resistor ( $V_R$ ) at P1 and P3.
7. Calculate the diode current  $I = V_R / R$
8. Measure the light emitting power using power meter.
9. Now step by step vary the POT 1 minimum level to maximum level and note down the corresponding readings.
10. Now plot the graph for Power Vs Current.

## RESULT

Thus the V-I and P-I characteristics of LED is plotted in the graph.

EX.NO:2

DATE:

## MODE CHARACTERISTICS OF FIBERS

AIM

To determine the number of modes present in the fiber.

### EQUIPMENTS REQUIRED

1. VOFT-02-A1
2. 1m plastic fiber cable
3. Numerical Aperture setup

### THEORY

For light rays to be propagated along a fiber they must fall within the fibers acceptance angle. The numerical aperture of a fiber is an indication of how much light a fiber can accept to propagate through it. The light transmitted inside a fiber account the total internal reflection, light travel not only along fiber's central axis but also various angles to centerline. The light rays fallen out of acceptance angle deviates from total internal reflection, they gets refracted from core-cladding boundary, provides losses to the information.

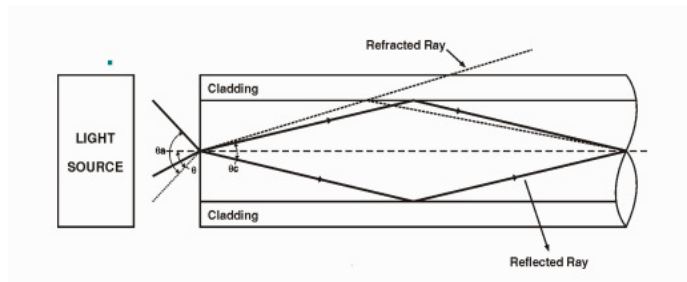

Acceptance Angle Theory

From the above figure, at the air-fiber interface, the beam at an angle  $\theta_a$  is the incident beam and the beam at an angle  $\theta_c$  is the launched one which is the refracted beam with respect to air-core interface and reflected beam with respect to the core-cladding interface respectively. Hence launched beam(critical angle) makes internal reflection whenever the incident beam( $\theta_a$ ) achieves an angle called acceptance angle.

---

## PROCEDURE

### Number of modes Calculation

1. Connect a 1m fiber cable between optical transmitter and NA setup as shown in figure .
2. Insert the fiber cable in numerical aperture setup as follows,
  - a. Unscrew the topside screw of NA setup.
  - b. Insert the fiber through topside hole.
  - c. Make the fiber cable end to 0.2 cm above from the base of NA setup.
3. Now a circular red color spot is shown in graph attached with the base of NA setup. Measure the circle in horizontally & vertically and find out mean radius of circle spot as,

$$r = (DE + BC)/4$$

Number of modes can be calculated by,

$$N = \frac{V^2}{2}$$

## RESULT

Thus the number of modes present in the fiber is determined.

**EX.NO:3**

**DATE:**

## **MEASUREMENT OF CONNECTOR AND BENDING LOSSES**

### **AIM**

To determine the attenuation & bending loss in the given plastic fiber with bends of various diameters and plot the performance graph.

### **EQUIPMENTS REQUIRED**

1. VOFT-02-A1, VOFT-02-B1.
2. Function Generation 1Hz - 2MHz
3. Two channel 20MHz oscilloscope
4. 1m & 3m plastic fiber cable
5. Coupling setup.

### **THEORY**

Measure the light power before it is directed into an optical fiber and then measure it again as it emerge from the fiber, would you expect to get same power? of course not, the power coming out of the fiber should be less than the power entering it, that's called attenuation.

In fiber - optic communication, attenuation is the decrease in light power or intensity during light propagation along an optical fiber. Here the light loss caused by the violation of total internal reflection concept during installation or manufacturing called bending loss and the light delays its power while propagating through the fiber called propagation loss.

CONNECTION DIAGRAM

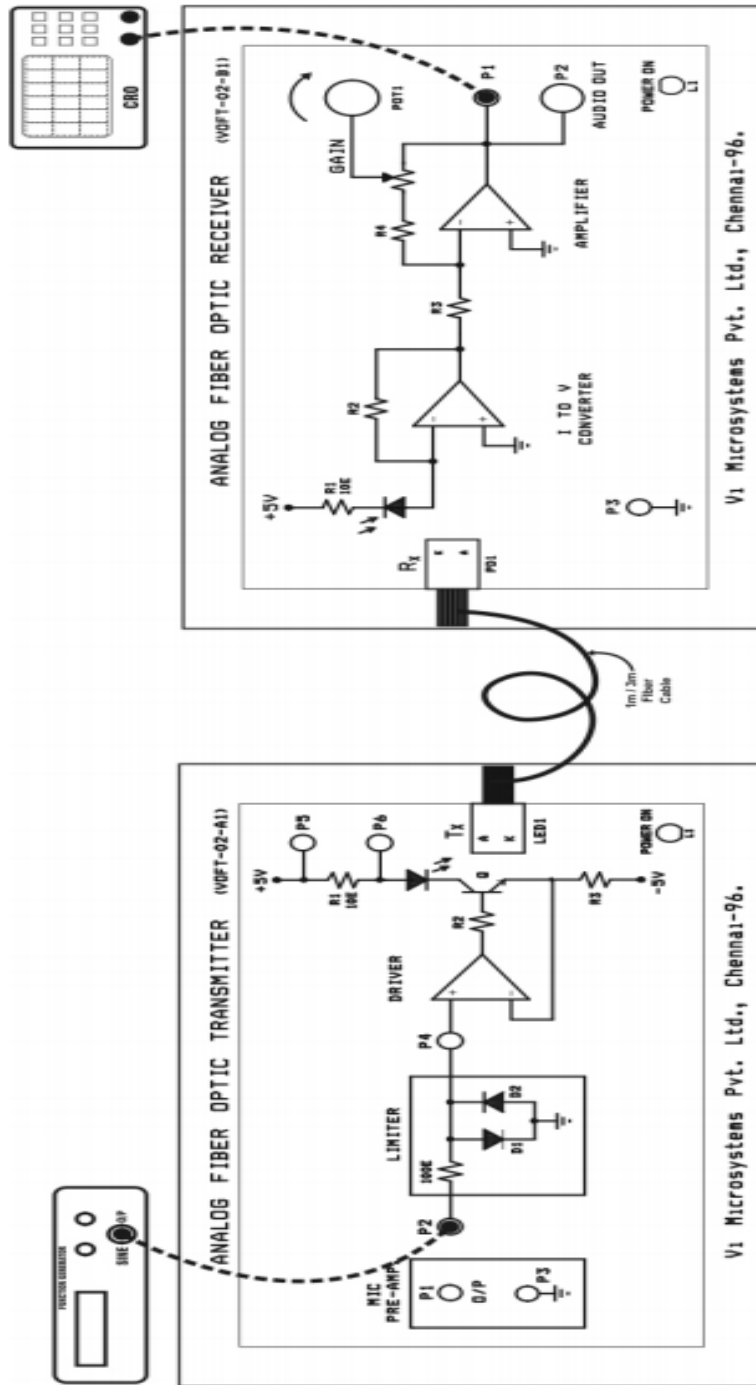

## TABULATION:

S.NO.	Input voltage (Volts)	Length of the cable in Meter	Output voltage

**Note: 1m output voltage is  $V_1$  and 3m is output voltage is  $V_2$**

## PROCEDURE

## Propagation Loss Measurement

1. Establish the analog link as suggest in experiment shown in figure with input signal amplitude and frequency of 1Vpp and 1KHz respectively.
2. Connect the output of VOFT-02-B1 (Test Point P1) to the channel 1 of oscilloscope using BNC - SP7 cable and keep fiber cable length of 1m between transmitter and receiver.
3. Turn the gain control POT at the receiver and set output amplitude level to 5Vpp, let us say it  $V_1$ . Now replace 1m fiber cable by 3m fiber cable without altering any other settings (receiver gain (or) input voltage).Measure the output voltage level for 3m fiber cable, let us say it  $V_2$ . The difference between the two readings is the extra loss in lost one due to the extra length of the fiber.
4. Determine the attenuation loss ' $\alpha$ ' for 1m fiber in dB/m,  $\alpha = -10 \log_{10} \left( \frac{V_2}{V_1} \right)$

**Bending Loss Measurement**

5. Establish the analog link as suggest in experiment 2. Set the input Sine wave amplitude and frequency to 1Vpp and 10KHz respectively, connect the output of VOFT-02-B1 (test point P1) with the oscilloscope using BNC - SP7 cable.
6. Keep fiber cable length of 1m between transmitter and receiver, turn receiver gain control POT and set the output amplitude level to 5Vpp. Now bend the 1m fiber cable to 5cm of diameter as suggest in figure. Note down output signal amplitude level for 5cm of fiber bending.
7. Reduce the bending diameter in steps of 1cm from 5cm and note down corresponding signal amplitude level for all bending diameter and tabulate.
8. Draw a graph for bending Vs gain as shown in figure.

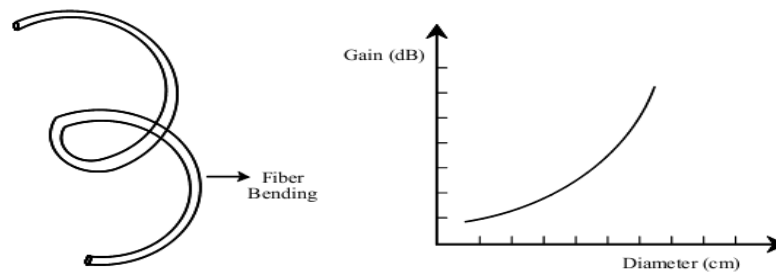

Fiber Bending and its Characteristics Curve

**TABULATION:**

S.NO.	Bending diameter cm	O/P Voltage volts	Gain = $10\log (V_0/V_{in})$ (dB)



### Coupling Loss Measurement

9. Establish the analog link as suggest in experiment - 2. Set the Input sine wave amplitude and frequency to 1Vpp and 10KHz respectively. Connect the output of VOFT-02-B1 (test point P1) board to oscilloscope using BNC - SP7 cable.
10. Connect the 1m fiber cable between transmitter and receiver, turn Gain control POT at receiver and set the output sine wave amplitude to 5Vpp
11. Replace the 3m fiber cable instead of 1m fiber cable, note down the output signal amplitude, let us say it  $V_{out}$ . Find out attenuation ,loss for 3m fiber cable as follows

$$\alpha_{3m} = -10 \log_{10} \left( \frac{V_2}{V_1} \right)$$

Convert this attenuation loss  $\alpha_{3m}$  (for 3 meter) into  $\alpha_{1m}$  (for 1meter) as follows,

$$\alpha_{1m} = \alpha_{3m} / [L_{3m} - L_{1m}]$$

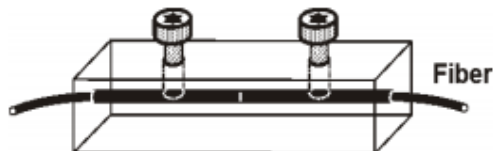

Coupling Loss Measurement

**TABULATION:**

S.NO.	Cable length (M)	Frequency KHz	I/P Voltage (volts in Vpp)	O/P Voltage (volts in Vpp)

**RESULT**

Thus the attenuation & bending loss in the given plastic fiber with bends of various diameters are calculated and the results plotted in the graph.

EX.NO : 4 a)

DATE:

## SETTING UP OF ANALOG OPTICAL LINK

### AIM

To set up an 850nm fiber optic analog link and measure the input and output wave forms.

### EQUIPMENTS REQUIRED

1. OFT -- 1
2. Two channel oscilloscope 50mhz
3. Function generator 1hz-10mhz
4. BNC cables

### THEORY

This experiment is designed to familiarize the user with OFT. An analog fiber optic link is to be set up in this experiment. The preparation of the optical fiber for coupling light into it and the coupling of the fiber to the LD and detector are described. The LD used is an 850nm LD. The fiber is a multimode fiber with a core diameter of 1000 $\mu$ m. the detector is a simple PIN detector. The LD optical power output is directly proportional to the current driving the LD. Similarly, for the PIN diode, the current is proportional to the amount of light falling on the detector. Thus, even though the LD and the PIN diode are non-linear devices, the current in the PIN diode is directly proportional to the driving current LD. This makes the optical communication system a linear system.

### PROCEDURE

1. Connections are given as per the block diagram. The 1m and 3m optical fiber provided with OFT are to be used.
2. Set the switch SW8 to the ANALOG position. Switch the power on. The power on switch is located at the top right hand corner.
3. Feed a 1Vp-p (peak-peak) sinusoidal signal at 1KHz [with zero d.c.], from a function generator, to the ANALOG IN post P11 using the following procedure:

- a. Connect a BNC-BNC cable from the function generator to the BNS socket I/03.
  - b. Connect the signal post I/03 to the ANALOG IN post P11 using a patch cord.
4. Connect one end of the 1m fiber to the LD source LD1 in the optical Tx1 block. Observe the light output [red tinge] at the other end of the fiber.
  5. Feed a 5Vp-p rectangular signal at P11. Observe the signal on the oscilloscope.
  6. Connect the other end of the fiber to the detector PD1 in the optical Rx1 block.

**CONNECTION DIAGRAM:**

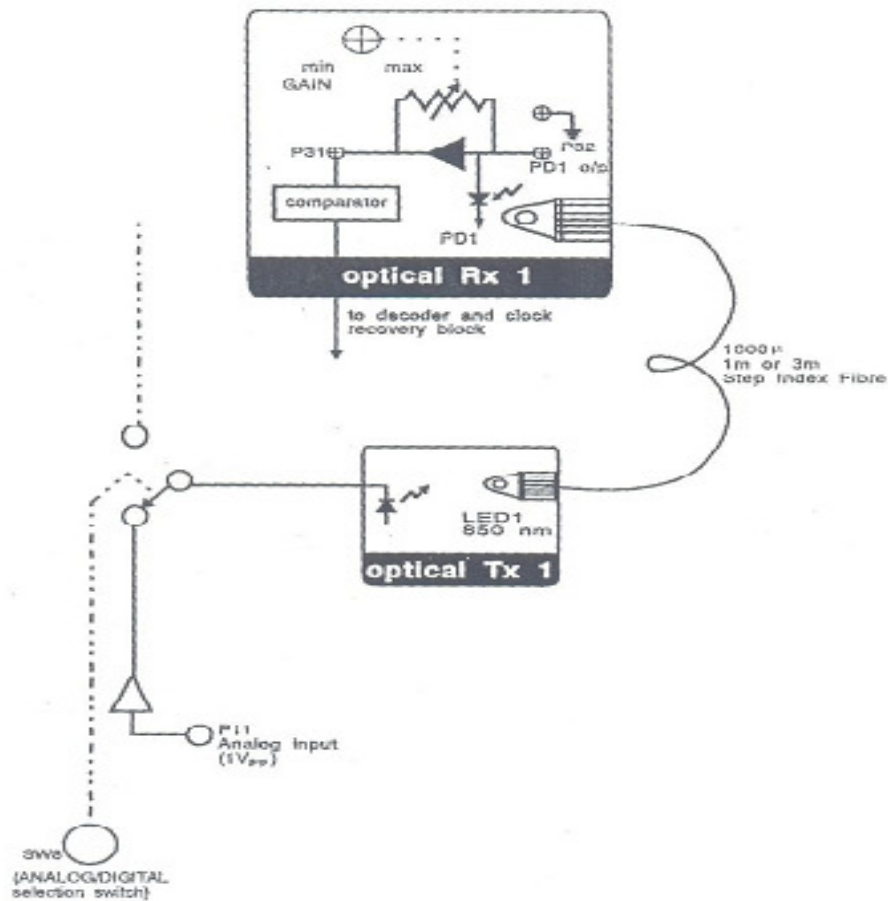

**TABULATION**

<b>S.NO.</b>	<b>Cable length (M)</b>	<b>Frequency in KHz</b>	<b>I/P Voltage (volts in Vpp)</b>	<b>O/P Voltage (volts in Vpp)</b>

**RESULT**

Thus the relationships between analog input and output waves are obtained.

EX.NO:4 b)

DATE:

## SETTING UP OF DIGITAL OPTICAL LINK

### AIM

To construct a digital communication optical link to transmit digital signals and plot the characteristics curve.

### EQUIPMENTS REQUIRED

- 1 OFT - 1
- 2 Two channel oscilloscope 20 MHz 1
- 3 Function generator 1Hz-10MHz 1
- 4 BNC cables -- 3

### THEORY

The OFT can be used to set up two fiber optic digital link, at a wavelength of 850nm. LD1, in the optical Tx1 block, is an 850 nm LD. PD1, in the optical Rx1 block, is a PIN detector which gives a current proportional to the optical power falling on the detector. The received signal is amplified and converted to a TTL signal using a comparator. The GAIN control plays a crucial role in this conversion. PD2, in the optical Rx2 block, is another receiver which directly gives out a TTL signal.

### PROCEDURE

1. The connections are made as per the block diagram.
2. Set the switch SW8 to the DIGITAL position.
3. Connect a 1m optical fiber LD1 and the PIN diode PD1.
4. Feed a TTL signal of about 20 KHz from the function generator to post B of S6.  
Use the BNC I/Os for feeding. Observe the received analog signal at the amplifier post P31 on channel 1 of the oscilloscope.
5. Observe the received signal at post A of S26 on channel 2 of the oscilloscope while still observing the signal at P31 on channel 1.

6. Set the gain such that the signal at P31 is about 2V. Observe the input signal from the function generator on channel 1 and the received TTL signal at post A of S26 on channel 2. Vary the frequency of the input signal and observe the output response.
7. Repeat Steps 4, 5 & 6 with the 3m fiber.

**OPTICAL DIGITAL LINK – BLOCK DIAGRAM**

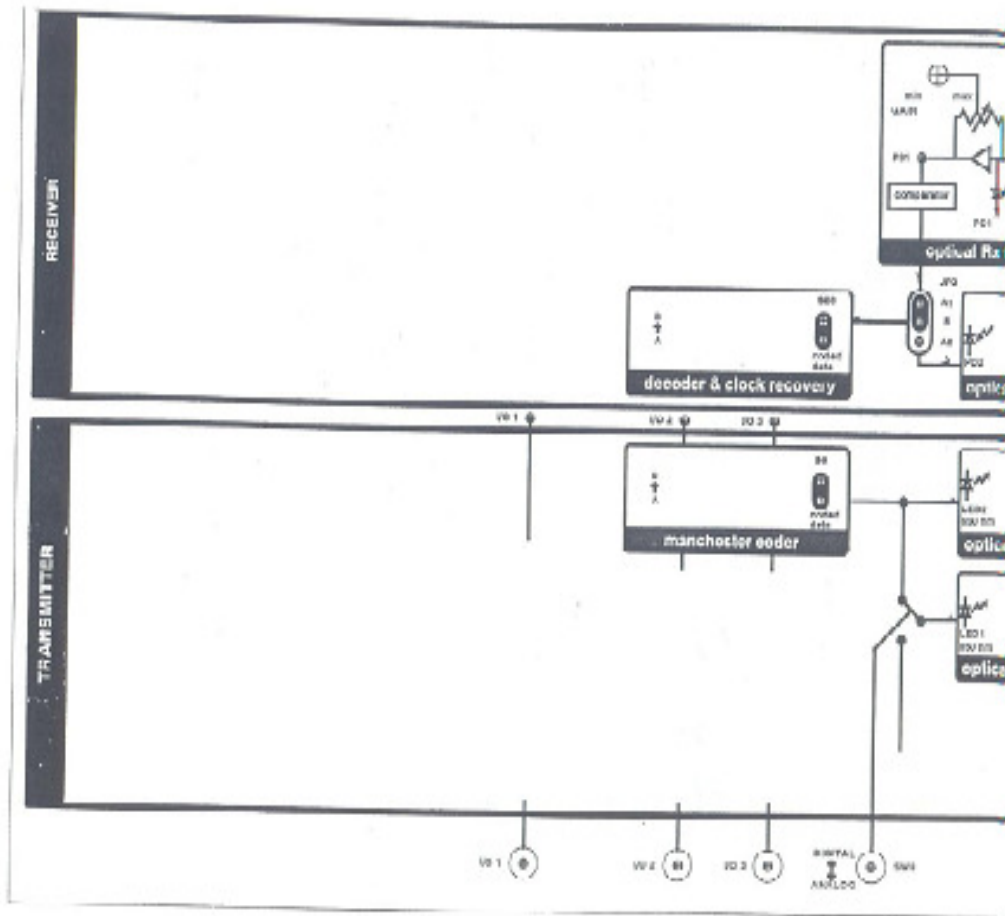

**RESULT**

Thus the transmission of digital signals input and output waveforms are measured and its plotted in the graph.



**EX.NO:5**

**DATE:**

**EYE PATTERN MEASUREMENT  
USING A HIGH BANDWIDTH OSCILLOSCOPE**

**AIM**

To compare the effect of EMI/RFI on a copper medium and an optical fiber medium.

**EQUIPMENTS REQUIRED**

1. OFT - 1
2. Two channel oscilloscope 20MHz
3. Function generator 1 Hz – 10 Hz
4. EMI unit - 1
5. Patch cord [supplied with OFT] 40 cm

**THEORY**

While optical fiber has established itself as the medium for long-haul wide-bandwidth communications, it has also made a significant impact in other application where neither the link nor the bandwidth requirement is large. This is because optical fiber is a dielectric medium, i.e. totally non-metallic. The signal propagating is optical and does not have any associated voltage or current. In many environment today, Electromagnetic Interference [EMI] and Radio Frequency Interference [RFI] have become a serious problem affecting even low bit-rate communication over short distances. Optical fiber, being totally dielectric, has immunity to EMI/RFI and is finding widespread application in such situation.

**PROCEDURE**

1. Set up the digital link using optical fiber.
2. Remove the shorting plugs of shorting links S6 in the Manchester coder block and S26 in the decoder & clock recovery block.
3. Reconnect the shorting plug at S6 and S26. Remove the fiber. Connect P12 in the electrical o/p block and P32 in optical Rx1 block using the 40cm patch

cord supplied with OFT. Adjust GAIN to ensure that the multiplexer / demultiplexer is working. The shorting of P12 and P32 establishes an analog link between the Tx and the Rx side on copper cable.

4. Using the signal at S7 as the external trigger for the oscilloscope, observe the signal at P31. The Rx data observed at the oscilloscope now starts with the digitized voice data in slot1. Increase the time scale to observe only on two bits on the scope.
5. Disconnect the patch cord at P12, insert it through the coil tube in the EMI unit supplied for interference generation, and reconnect it at P12 with the coil now around the wire. Connect the interference coil to a function generator and excite it with a sinusoidal signal of around 100 KHz at around 5V p-p, with zero D.C. Observe the signal P31.
6. As the interference on the incoming signal increases the EYE opening decreases with the frequency of the interfering sinusoidal signal fixed [say at 500 KHz], increase its amplitude without disturbing the coil.
7. Repeat steps 6 and 7 for several frequencies between 500 KHz and 1 MHz and note the voltages required for the interference to affect the working of the multiplexer.
8. Remove the patch cord containing P12 and P32. Put the interfering coil around a 1m optical fiber and set up the optical link at 850 nm.

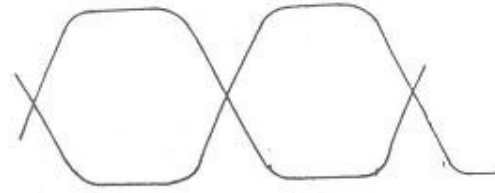

Eye Diagram

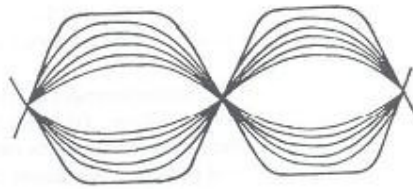

Eye Diagram in Presence of Interference

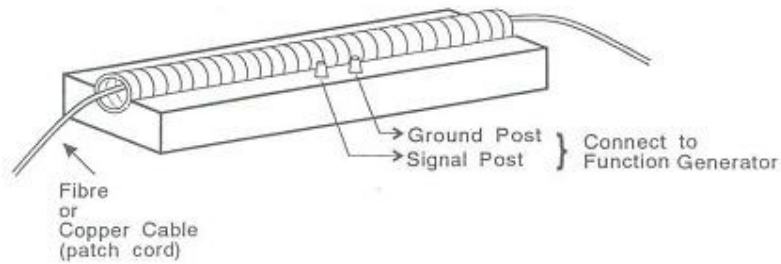

EMI Coil Unit

## RESULT

Thus the effect of EMI/RFI on a copper medium and an optical fiber medium sinusoidal signal was drawn in the graph.

EX.NO:6

DATE:

## NUMERICAL APERTURE DETERMINATION FOR FIBERS

### AIM

To calculate the numerical aperture and acceptance angle for the given optical fiber.

### EQUIPMENTS REQUIRED

1. VOFT-02-A1
2. 1m plastic fiber cable
3. Numerical Aperture setup

### THEORY

For light rays to be propagated along a fiber they must fall within the fibers acceptance angle. The numerical aperture of a fiber is an indication of how much light a fiber can accept to propagate through it. The light transmitted inside a fiber account the total internal reflection, light travel not only along fiber's central axis but also various angles to centerline. The light rays fallen out of acceptance angle deviates from total internal reflection, they gets refracted from core-cladding boundary, provides losses to the information.

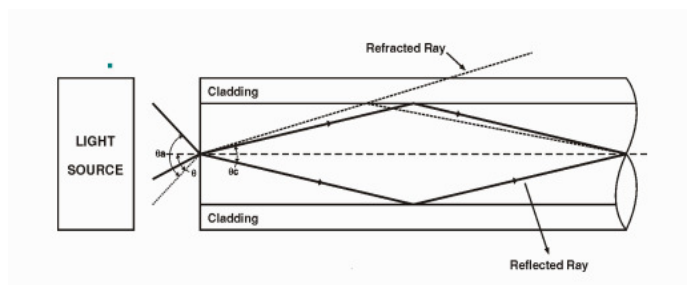

### Acceptance Angle Theory

From the above figure, at the air-fiber interface, the beam at an angle  $\theta_a$  is the incident beam and the beam at an angle  $\theta_c$  is the launched one which is the refracted beam with respect to air-core interface and reflected beam with respect to the core-cladding interface respectively. Hence launched beam(critical angle) makes internal reflection whenever the incident beam( $\theta_a$ ) achieves an angle called acceptance angle.

## PROCEDURE

### Numerical Aperture and Acceptance Angle

1. Connect a 1m fiber cable between optical transmitter and NA setup as shown in figure .
2. Insert the fiber cable in numerical aperture setup as follows,
  - a. Unscrew the topside screw of NA setup.
  - b. Insert the fiber through topside hole.
  - c. Make the fiber cable end to 0.2 cm above from the base of NA setup.
3. Now a circular red color spot is shown in graph attached with the base of NA setup. Measure the circle in horizontally & vertically and find out mean radius of circle spot as,

$$r = (DE + BC)/4$$

4. Find out the numerical aperture for a distance as,

$$NA = \frac{r}{\sqrt{r^2 + d^2}}$$

where, d is distance in cm, r is mean radius of circle spot.

5. Measure the NA for other distances of 0.4 cm, 0.6cm, 0.8cm and 2cm, finally take an average for all readings of NA which is the Numerical Aperture for the given plastic fiber. Typical fiber's NA is 0.5 to 0.6.
6. Find-out the acceptance angle as follows,

$$\theta_a = \sin^{-1}(NA)$$

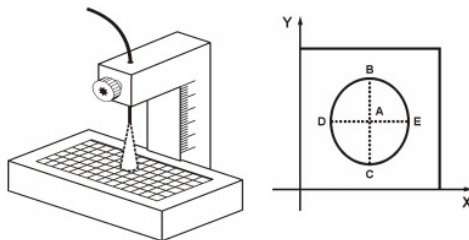

**Numerical aperture set up**

**TABULATION**

S.NO.	Distance(d) in cm	Mean radius (r) in cm	Numerical Aperture

7. The refractive index of cladding( $n_2$ ) for given fiber is 1.402, now find out the refractive index of the core( $n_1$ ) using following

formula  $NA = \sqrt{n_1^2 - n_2^2}$

Where  $n_1$  is refractive index of core,  $n_2$  is refractive index of Cladding ,& NA is Numerical Aperture of fiber.

**RESULT**

Thus the numerical aperture and the acceptance angle for the given optical fiber is calculated.

Numerical aperture \_\_\_\_\_

Acceptance angle \_\_\_\_\_

**EX.NO:7**

**DATE:**

## **ATTENUATION MEASUREMENT**

### **AIM**

To measure the attenuation losses in the given optical fiber.

### **EQUIPMENTS REQUIRED**

1. VOFT-02-A1, VOFT-02-B1.
2. Function Generation 1Hz - 2MHz
3. Two channel 20MHz oscilloscope
4. 1m & 3m plastic fiber cable
5. Coupling setup.

### **THEORY**

Measure the light power before it is directed into an optical fiber and then measure it again as it emerge from the fiber, would you expect to get same power? of course not, the power coming out of the fiber should be less than the power entering it, that's called attenuation.

In fiber - optic communication, attenuation is the decrease in light power or intensity during light propagation along an optical fiber. Here the light loss caused by the violation of total internal reflection concept during installation or manufacturing called bending loss and the light delays its power while propagating through the fiber called propagation loss.

CONNECTION DIAGRAM

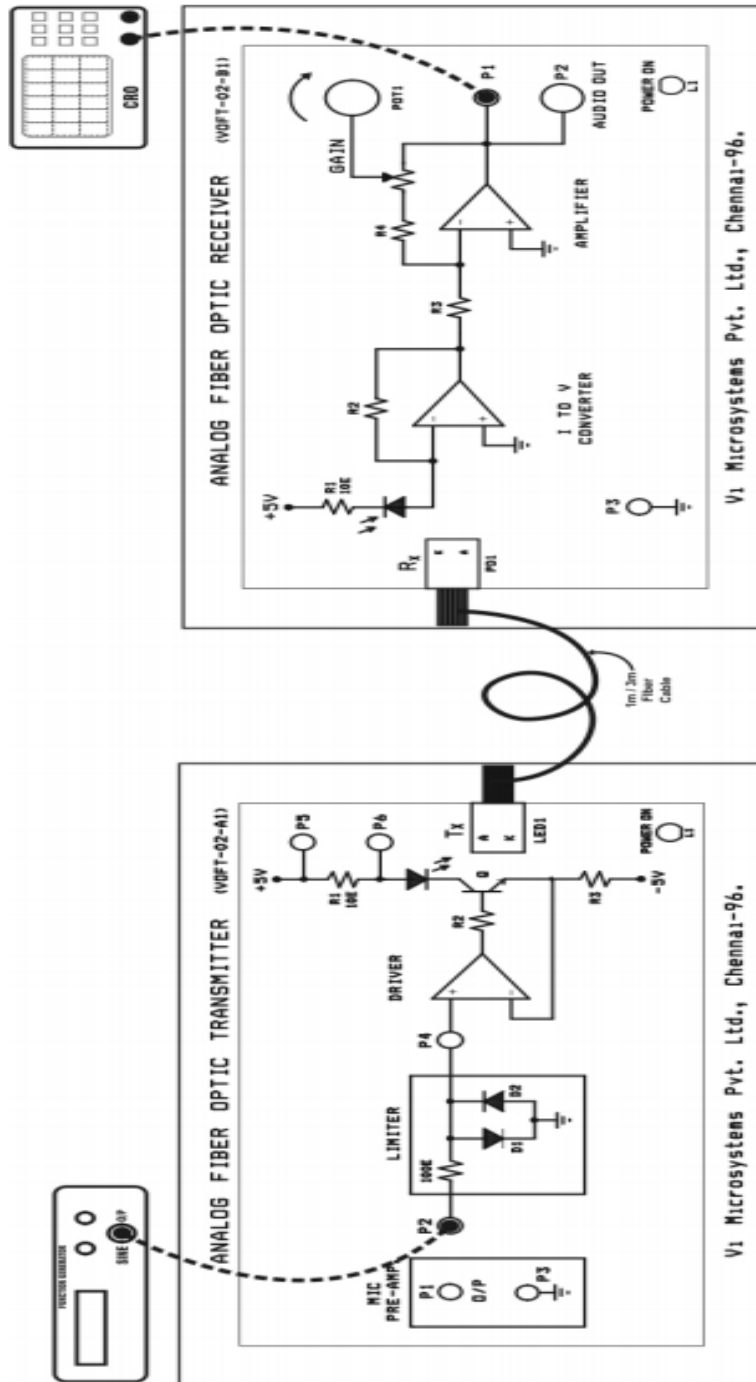



## TABULATION:

S.NO.	Cable length (M)	Frequency KHz	I/P Voltage (volts in Vpp)	O/P Voltage (volts in Vpp)

**Note: 1m output voltage is  $V_1$  and 3m is output voltage is  $V_2$**

## PROCEDURE

1. Establish the analog link as suggest in experiment shown in figure with input signal amplitude and frequency of 1Vpp and 1KHz respectively.
2. Connect the output of VOFT-02-B1 (Test Point P1) to the channel 1 of oscilloscope using BNC - SP7 cable and keep fiber cable length of 1m between transmitter and receiver.
3. Turn the gain control POT at the receiver and set output amplitude level to 5Vpp, let us say it  $V_1$ . Now replace 1m fiber cable by 3m fiber cable without altering any other settings (receiver gain (or) input voltage). Measure the output voltage level for 3m fiber cable, let us say it  $V_2$ . The difference between the two readings is the extra loss in lost one due to the extra length of the fiber.
4. Determine the attenuation loss ' $\alpha$ ' for 1m fiber in dB/m,  $\alpha = -10 \log_{10} \left( \frac{V_2}{V_1} \right)$

## RESULT

Thus the attenuation losses for given optical fibers are measured and verified.

**EX.NO:8**

**DATE:**

## **V-I CHARACTERISTICS OF GUNN OSCILLATOR**

**AIM:**

To obtain the VI Characteristics of a Gunn diode acting as an oscillator and measure the threshold voltage.

### **EQUIPMENTS REQUIRED**

1. Gunn Power Supply GS-610
2. Gunn Oscillator XG-11
3. Isolator XI-621
4. Frequency Meter XF-710
5. Matched Termination XL-400
6. Oscilloscope
7. BNC Cable

### **THEORY**

The Gunn Oscillator is based on negative differential conductivity effect in bulk semiconductors which has two conduction bands separated by an energy gap (greater than thermal energies). A disturbance at the cathode gives rise to high field region which travels towards the anode. When this field domain reaches the anode, it disappears and another domain is formed at the cathode and starts moving towards anode and so on. The time required for domain to travel from cathode to anode (transit time) gives oscillation frequency.

In a Gunn Oscillator, the Gunn diode is placed in a resonant cavity. The Oscillator frequency is determined by cavity dimensions. Although Gunn Oscillator can be amplitude modulated with the bias voltage. We have used a PIN modulator for square wave modulation of the signal coming from Gunn diode.

A measure of the square wave modulation capability is the modulation depth i.e. the output ratio between ON and OFF state.

**PROCEDURE**

1. Arrange the bench setup as shown in figure.
2. Switch on the gunn power supply.
3. Initially give some gunn bias voltage, fix the attenuation and adjust the frequency meter to give maximum output.
4. Now keep the gunn bias in minimum position around 0.5V and increase it slowly. Do not exceed the bias voltage above 10V
5. For difference values of voltage measure the gunn diode current.
6. From the tabulation observed, plot the V-I characteristics.
7. Measure the threshold voltage which corresponds to maximum current

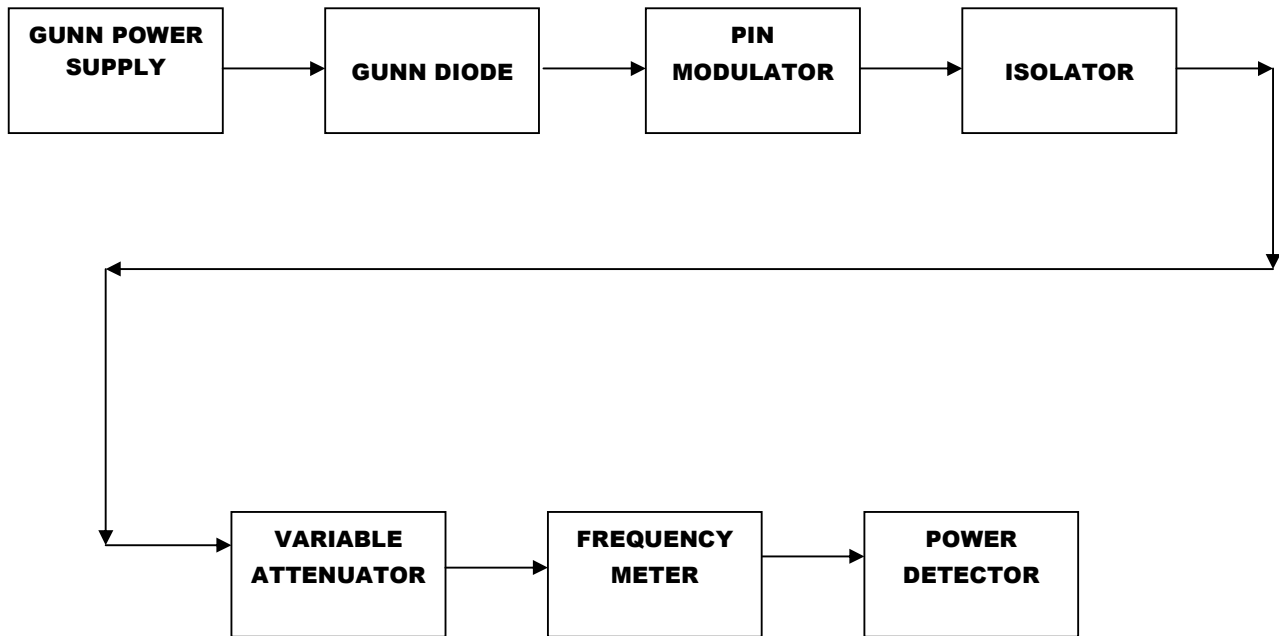

**Note:** Do not keep gunn bias knob position at threshold position for more than 10-15 seconds. reading should be obtained as fast as possible, otherwise due to excessive heating and gunn diode may burn.

**TABULATION**

S.No.	GUNN BIAS VOLTAGE (V in Volts)	OUTPUT CURRENT (I in mA)

**Model Graph**

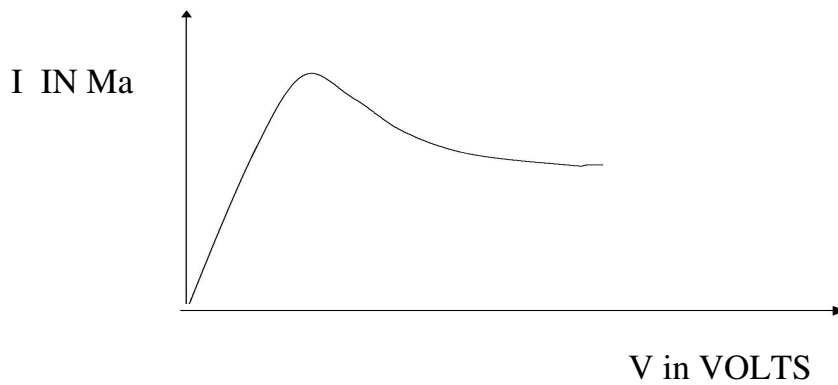

**RESULT**

Thus the VI Characteristics of a Gunn diode acting as an oscillator and measured the threshold voltage is \_\_\_\_\_

**EX.NO:9**

**DATE:**

## **MODE CHARACTERISTICS OF REFLEX KLYSTRON**

**AIM**

To construct a microwave bench set up using Reflex Klystron as source and perform the mode characteristics.

### **EQUIPMENTS REQUIRED**

1. Klystron Power Supply,
2. Klystron with mount,
3. Isolator,
4. Frequency meter
5. Variable Attenuator
6. Slotted section with Probe carriage
7. CRO
8. Movable Short.

### **THEORY**

Klystron is a microwave vacuum tube employing velocity modulation. These electrons move towards the repeller(ie) the electrons leaving the cavity during the positive half cycle are accelerated while those during negative half cycle are decelerated. The faster ones penetrate further while slower ones penetrate lesser in the field of repeller voltage. But, faster electrons leaving the cavity take longer time to return and hence catch up with slower ones. In the cavity the electrons bunch and interact with the voltage between the cavity grids. It consists of an electron gun producing a collimated electron beam.

It bunches pass through grids at time the grid potentials is such that electrons are decelerated they give by energy. The electrons are then collected by positive cavity wall near cathode. To protect repeller from damage, repeller voltage is applied before

accelerating voltage.

**PROCEDURE**

- i) Assemble the components as shown in fig.
- ii) After following the necessary precautions, the Klystron Power Supply is switched ON.
- iii) To obtain peak voltage, the attenuator is positioned at it's minimum attenuation.
- iv) Vary the repeller voltage from it's maximum negative value and increase it in steps on N and record output power and frequency.
- v) The frequency is measured by tuning the basic frequency meter to have a dip in the output voltage each time.
- vi) The frequency meter is detuned before measuring the output power each time.
- vii) The mode characteristics of Reflex Klystron is plotted. (i.e. Output Voltage Vs Repeller voltage and Frequency Vs Repeller voltage)

**MODE CHARACTERISTICS OF REFLEX KLYSTRON**

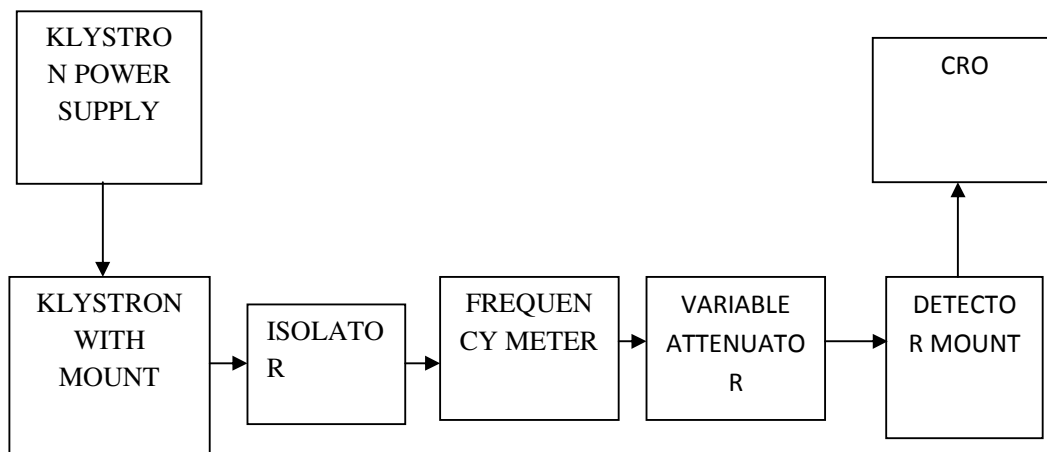

**MODEL GRAPH :**

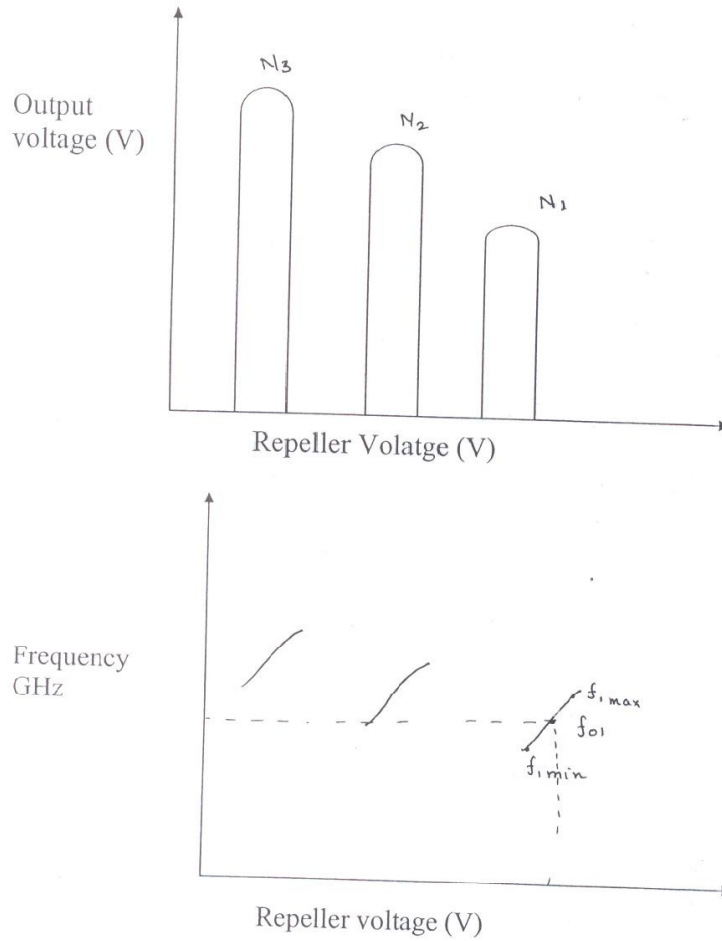

**TABULATION**

Mode	Frequency GHz	Repeller voltage V	Output Voltage (mV)
1			
2			
3			

**BASIC PRECAUTIONS**

1. During operation of Klystron, repeller does not carry any current and as such it may severely be damaged by electron bombardment. To protect repeller from such damage, the repeller negative voltage is always applied before anode voltage.
2. The repeller voltage should be varied in one direction to avoid hysteresis in klystrons
3. The heater voltage should be applied first and cooling should be provided simultaneously after some time other voltages should be applied taking precaution(i).
4. While measuring power, the frequency meter should be detuned each time because there is a dip in the output power when the frequency is tuned.
5. To avoid loading of the klystron an isolator/attenuation should invariably be used between klystron and the rest of the set-up.

**CALCULATIONS**

- (i) Knowing mode top voltages of two adjacent modes, mode numbers of the modes is computed from the equation,

$$\frac{N_1}{N_2} = \frac{V_1}{V_2} = \frac{(n + 1) + \frac{3}{4}}{n + \frac{3}{4}}$$

where

$V_1$  and  $V_2$  are the values of repeller voltages required to operate the klystron in mode numbers  $N_1$  and  $N_2$ .

- (ii) The transit time of each mode is calculated from

$$t_t = \frac{n + \left(\frac{3}{4}\right)}{f_0}$$

$f_0 \rightarrow$  frequency of microwave operation in one mode.



- (iii) The transit time of each mode is found from

$$t_{t1} = \frac{N_1}{f_{01}}, t_{t2} = \frac{N_2}{f_{02}}$$

- (iv) ETR – Electronic tuning range i.e, the frequency band from one end of the mode to another is calculated by

$$ETR = f_{1max} - f_{1min} \text{ for } N_1 \text{ mode (GHz)}$$

$$ETR = f_{1max} - f_{1min} \text{ for half power frequencies}$$

- (v) ETS – Electronic tuning sensitivity

$$ETS = \frac{f_2 - f_1}{V_2 - V_1}$$

$f_{1max}, f_{1min} \rightarrow$  half power frequency  $V_{1max}, V_{1min} \rightarrow$  corresponding repeller voltages for a particular mode.

- (vi) Efficiency of Klystron

$$\eta = \frac{P_0}{V_b I_b} \times 100\%$$

## RESULT

Thus the mode characteristics of Reflex Klystron are plotted in graph.

**EX.NO:10**

**DATE:**

## **WAVE LENGTH & FREQUENCY MEASUREMENT**

### **AIM**

To construct a microwave bench set up using Reflex Klystron to calculate the indirect frequency and guide wavelength.

### **EQUIPMENTS REQUIRED**

1. Microwave source (klystron power supply)
2. Klystron Mount
3. Isolator
4. Variable Attenuator
5. Frequency meter
6. Slotted section
6. Matched Termination
7. VSWR meter (or) CRO

### **THEORY**

For dominant TE<sub>10</sub> mode Rectangular waveguide  $\lambda_0$ ,  $\lambda_c$ ,  $\lambda_g$  are related as below

$$\frac{1}{\lambda_0^2} = \frac{1}{\lambda_g^2} + \frac{1}{\lambda_c^2}$$

Where  $\lambda_0$  is free space wave length

$\lambda_g$  is guide wavelength

$\lambda_c$  is cut off wavelength

For TE 10 mode  $\lambda_c=2a$  where a is broader dimension of waveguide

The operating frequency  $f = c \sqrt{\left(\frac{1}{\lambda_g^2}\right) + \left(\frac{1}{\lambda_c^2}\right)}$

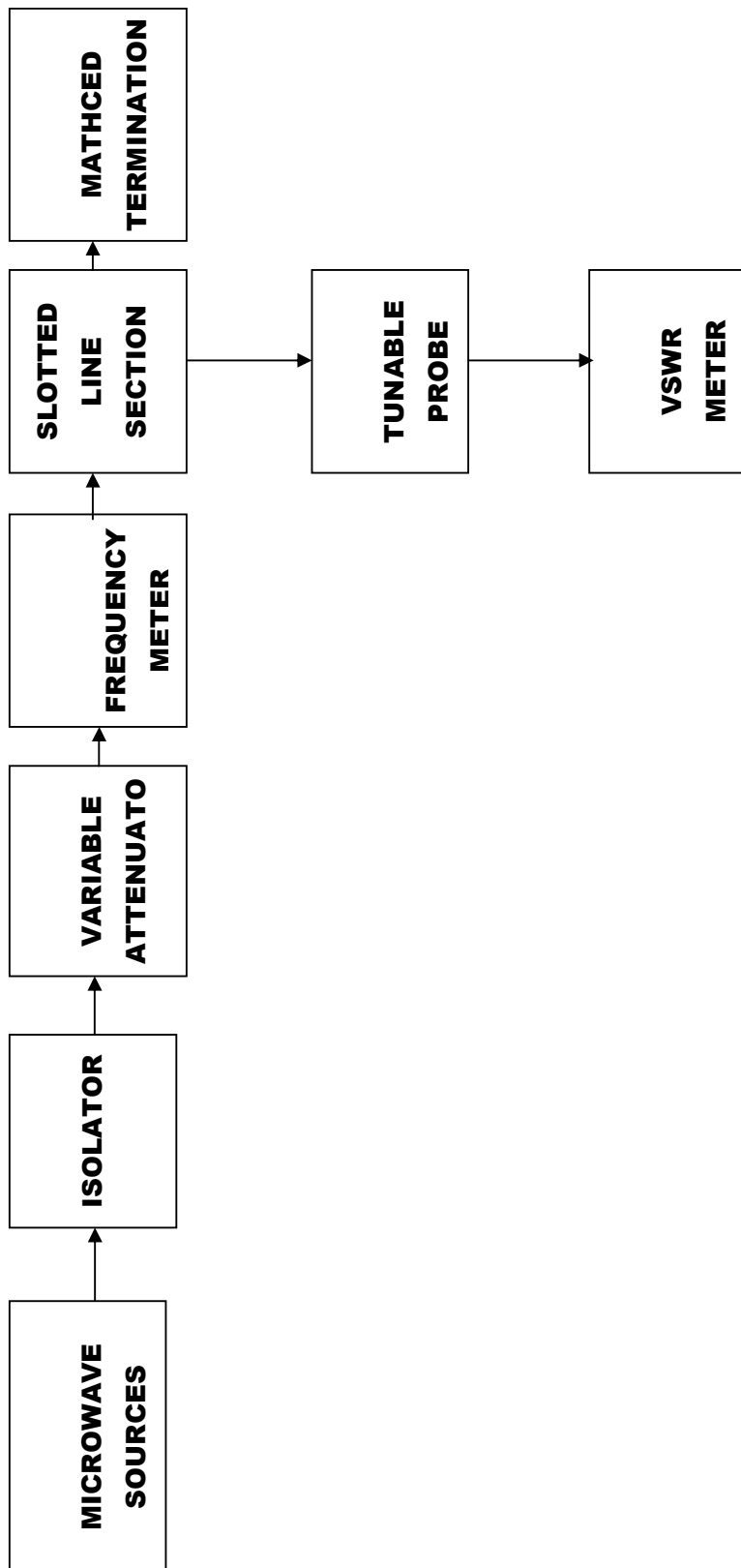

## PROCEDURE

1. Set up the components and equipment as shown in figure.
2. Set the variable attenuator at minimum attenuation position.
3. Keep the control knobs of VSWR Meter as below:
  - Range - 50dB
  - Input Switch - Crystal low Impedance
  - Meter Switch - Normal Position
  - Gain( Coarse Fine) - Mid Position
4. Keep the control knobs Klystron Power Supply as below
  - Beam Voltage - OFF
  - Mod-Switch - AM
  - Beam Voltage Knob - Fully Anticlockwise
  - Reflector Voltage - Fully Clockwise
  - AM Amplitude Knob- Around Fully Clockwise
  - AM Frequency Knob- Around Mid Position
5. Switch ON the Klystron Power Supply, VSWR meter and Cooling fan.
6. Switch ON the beam voltage switch and set beam voltage at 300V with the help of beam voltage knob.
7. Adjust the reflector voltage to get some deflection in VSWR meter.
8. Maximize the deflection with AM amplitude and frequency control knob of power supply.
9. Tune the plunger of Klystron mount for maximum deflection in VSWR meter.
10. Tune the reflector voltage knob for maximum deflection.
11. Tune the probe for maximum deflection in VSWR meter.
12. Tune the frequency meter knob to get a dip on the VSWR scale and note down the frequency directly from frequency meter.

13. Replace the termination with movable short, and detune the frequency meter.
14. Move the probe along the slotted line. The deflection in VSWR meter will vary.  
Move the probe to a minimum deflection position, to get accurate reading. If necessary increase the VSWR meter range dB switch to higher position. Note and record the probe position.
15. Move the probe to next minimum position and record the probe position again.
16. Calculate the guide wavelength as twice the distance between two successive minimum positions obtained as above.
17. Measure the guide waveguide inner broad dimension 'a' which will be around 22.86mm for X-Band.
18. Calculate the frequency by following equation.  
 $f=c/\lambda$  where  $c=3*10^8$  meter/sec.
19. Verify with frequency obtained by frequency meter.
20. Above experiment can be verified at different frequencies.

### **OBSERVATIONS**

Beam Voltage =

Repeller Voltage =

Frequency reading from frequency meter =

First voltage minima position (d1) =

Second voltage minima position (d2) =

## CALCULATIONS

$$\lambda_g = 2(d_1 - d_2)$$

$$\lambda_c = 2a \text{ where } a = 22.86\text{mm for X band}$$

$$\frac{1}{\lambda_0^2} = \frac{1}{\lambda_g^2} + \frac{1}{\lambda_c^2}$$

$$\lambda_0 =$$

$$f = c / \lambda_0$$

## RESULT

Thus the indirect frequency and guide wavelength are calculated.

EX.NO:11

DATE:

### VSWR MEASUREMENT

#### AIM

To measure the standing wave ratio and reflection coefficient in a micro wave transmission line.

#### EQUIPMENTS REQUIRED

1. Microwave source (klystron power supply)
2. Klystron Mount
3. Isolator
4. Variable Attenuator
5. Slotted section
6. Matched Termination
7. VSWR meter (or) CRO

#### EXPERIMENTAL SETUP

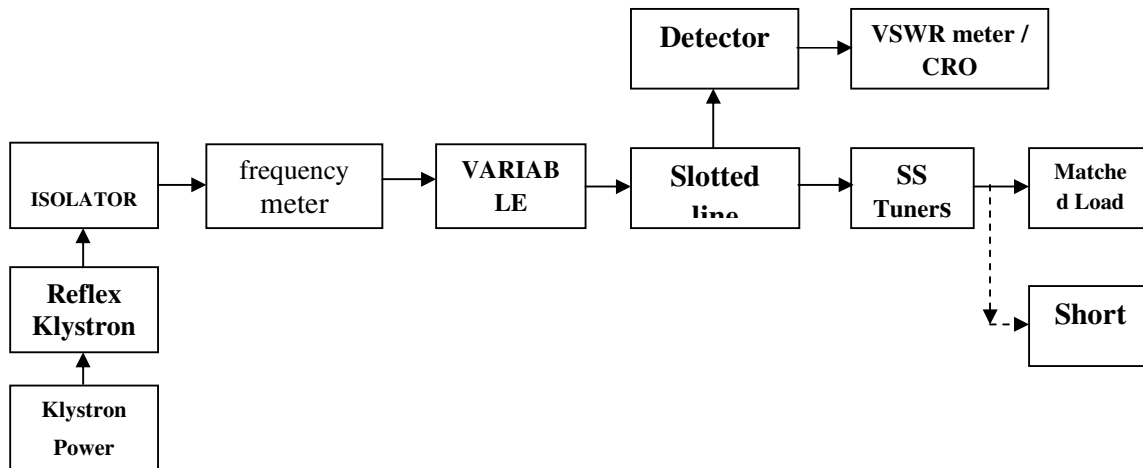

## PROCEDURE

1. Set up the components and equipments as shown in figure.
2. Keep the variable attenuator in the minimum attenuation position.
3. Keep the control knobs of VSWR meter as below
  - Range dB - 40 db/50db
  - Input Switch - Low Impedance
  - Meter Switch - Normal
  - Gain (Coarse- Fine) - Mid Position Approx.
4. Keep the control knobs of Klystron Power Supply as below
  - Beam Voltage - OFF
  - Mod- Switch - AM
  - Beam Voltage Knob - Fully Anticlockwise
  - Reflector Voltage Knob - Fully Clockwise
  - AM-Amplitude Knob - Around Fully Clockwise
  - AM- Frequency Knob - Mid position
5. Switch ON the Klystron Power Supply, VSWR meter and Cooling Fan.
6. Switch ON the Beam Voltage Switch position and set the beam voltage at 300V.
7. Rotate the reflector voltage knob to get deflection in VSWR meter.
8. Tune the output by turning the reflector voltage knob, amplitude and frequency of AM Modulation.
9. Tune the plunger of Klystron Mount and Probe for maximum deflection in VSWR meter.
10. If required, change the range db- switch variable attenuator position and gain control knob to get maximum deflection in the scale of VSWR meter.
11. As you move probe along the slotted line, the deflection in VSWR meter will change.

### A. Measurement of Low and Medium VSWR

1. Move the probe along the slotted line to get maximum deflection in VSWR meter.
2. Adjust the VSWR meter gain control knob or variable attenuator until the meter indicates 1.0 on normal VSWR meter scale.



3. Keep all the control knobs as it is, move the probe to the next minimum position.  
Read the VSWR on scale.
4. Repeat the above step for change of SS Tuner probe depth and record the corresponding VSWR.
5. If the VSWR is between 3.2 and 10, change the range db switch to next higher position and read the VSWR on second VSWR scale of 3 to 10.

**B. Measurement of High VSWR(Double Minima Method)**

1. Set the depth of SS Tuner slightly more for maximum VSWR.
2. Move the probe along with slotted line until a minimum is indicated.
3. Adjust the VSWR meter gain control knob and variable attenuator to obtain a reading of 3db in the normal dB scale (0 to 10dB) of VSWR meter.
4. Move the probe to the left on the slotted line full scale deflection is obtained on 0-10dB scale. Note and record the probe position on slotted line. Let it be d1.
5. Repeat the steps 3 and then move the probe right along the slotted line until full scale deflection is obtained on 0-10 dB in normal dB scale. Let it be d2.
6. Replace the SS Tuner and termination by movable short.
7. Measure the distance between the successive minima positions of the probe. Twice this distance is guide wavelength  $\lambda_g$ .
8. Compute SWR from the following equation

$$SWR = \lambda_g / \pi (d1 - d2)$$

**FORMULA**

$$VSWR = V_{max} / V_{min}$$

$$|\delta| = \frac{(S - 1)}{(S + 1)}$$

**Measurement of VSWR by Double minimum feed**

Sl.No	Frequency	Matched Load			Short		
		d <sub>1</sub>	d <sub>2</sub>	VSWR	d <sub>1</sub>	d <sub>2</sub>	VSWR
1							
2							
3							
4							
5							

**MEASUREMENT OF VSWR BY CRO**

1. Connect detector output to CRO
2. Move the probe along the slotted line for a typical frequency.
3. Measure V<sub>max</sub> and V<sub>min</sub>.
4. Change the frequency and repeat the above steps.
5. Tabulate the results .
6. Find the VSWR from  $\frac{V_{max}}{V_{min}}$

**Measurement of VSWR using CRO**

Sl.No	Frequency	Matched Load			Short		
		V <sub>max</sub>	V <sub>min</sub>	VSWR	V <sub>max</sub>	V <sub>min</sub>	VSWR
1							
2							
3							
4							
5							

**RESULT**

Thus the standing wave ratio and reflection coefficient are measured.

**EX.NO:12**

**DATE:**

## **ATTENUATION MEASUREMENT**

**AIM**

To measure the attenuation induced by the given wave guide.

### **EQUIPMENTS REQUIRED**

1. Microwave source (klystron power supply)
2. Klystron Mount
3. Isolator
4. Variable Attenuator
5. Frequency meter
6. DUT (Fixed Attenuator)
7. Power Detector

### **FORMULA**

$$\text{Attenuation} = 20 \log (V1 / V2) \text{ db}$$

### **PROCEDURE**

1. Arrange the bench setup as shown in figure 1 and measure the input power entering into the wave guide (P1).
2. Reconnect the circuit as shown in the figure 2 and find the power (P2) at the output of the given wave guide.
3. Using formula find the attenuation introduced by the wave guide.

**BENCH SETUP DIAGRAM OF ATTENUATION MEASUREMENT:**

**FIGURE – 1 (Without DUT)**

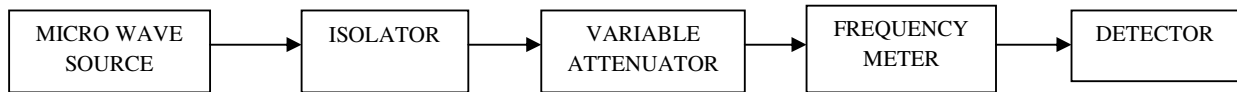

**Figure-2 (With DUT)**

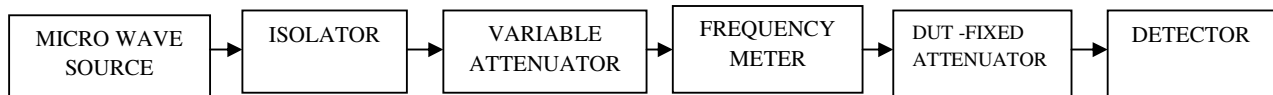

**RESULT**

Thus the attenuation induced by the given wave guide was found and verified.

EX.NO:13

DATE:

### DIRECTIONAL COUPLER

#### AIM

To construct a microwave bench set up using a Multi hole Directional coupler and measure the performance parameters (i) Directivity (ii) Coupling factor (iii) Isolation (iv) Insertion loss and find its S-matrix.

#### EQUIPMENTS REQUIRED

1. Klystron power supply
2. Klystron Tube
3. Klystron Mount
4. Isolator
5. Frequency Meter
6. Variable Attenuator
7. Slotted section
8. Detector Mount
9. Wave guide Stands
10. VSWR Meter
11. BNC Cable
12. CRO
13. Directional Coupler

#### THEORY

- ❖ It is a passive four – port devices.
- ❖ It is a reciprocal device.
- ❖ It consists of a primary guide with port1 and port 2 and a secondary guide with port 3 and 4.
- ❖ A typical directional coupler shown in fig .

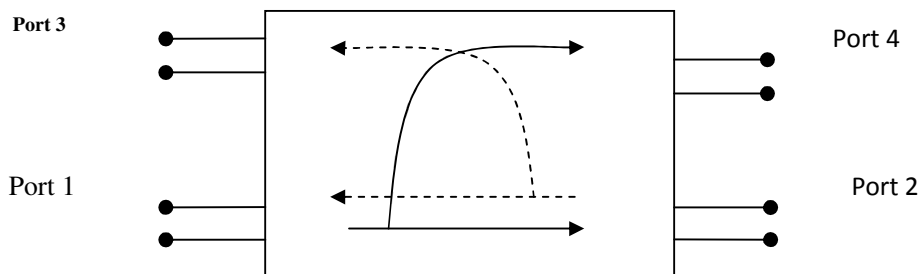

- ❖ It is made of two connected wave guides one of the wave guides curves away .
- ❖ The wave guides are coupled through holes between them.
- ❖ The directional coupler is said to be consisting of main arm and an auxiliary arm shown in fig.
- ❖ The amount of power coupled to the auxiliary arm depends on the number of holes and their size.
- ❖ The matched termination absorbs the power reaching it with out reflection.
- ❖ The coupler is used to find the power reflection coefficient in a wave guide and find out incident and reflected power values.
- ❖ The power at port 4 and port 2 have phase difference of  $90^0$ . Similarly the power at port 3 and 1 have phase difference of  $90^0$  when the propagation is in reverse direction.
- ❖ The guides 1-2 and 3-4 are identical. Any one of them can be used as primary and the other acts the auxiliary guide.
- ❖ The directional couplers are described by coupling factor directivity and VSWR.

**The parameters of Directional couplers.**

1. Coupling Factor(C)                       $C = 10 \log_{10} \left( \frac{P_i}{P_a} \right), dB$

$P_i$  = input power to the primary guide

$P_a$  = output power at auxiliary guide

2. Directivity (D)                       $D = 10 \log_{10} \left( \frac{P_{af}}{P_{ar}} \right), Db$

$P_{af}$  = power of the auxiliary arm due to power in forward direction

$P_{ar}$  = power of the auxiliary arm due to power in reverse direction

**EXPERIMENTAL SETUP**

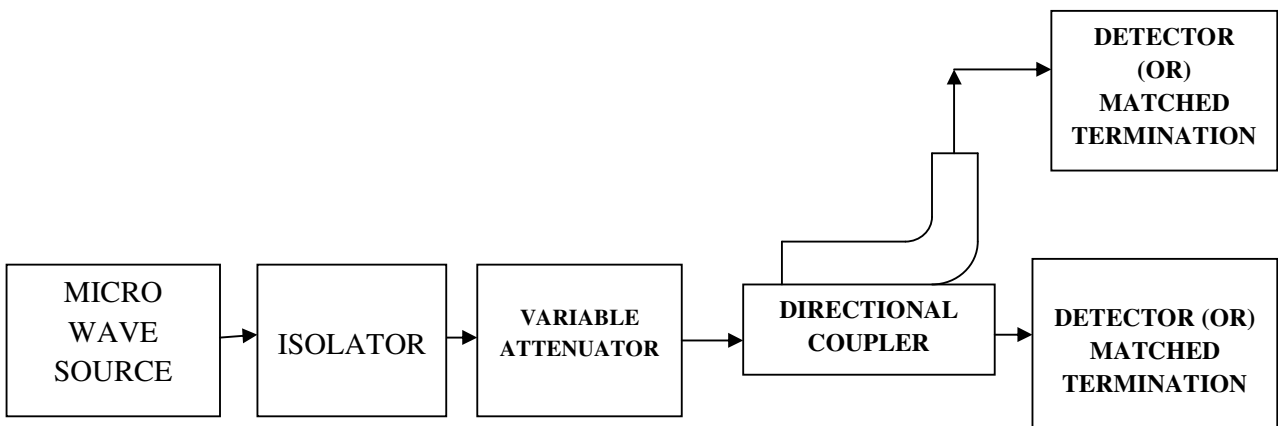

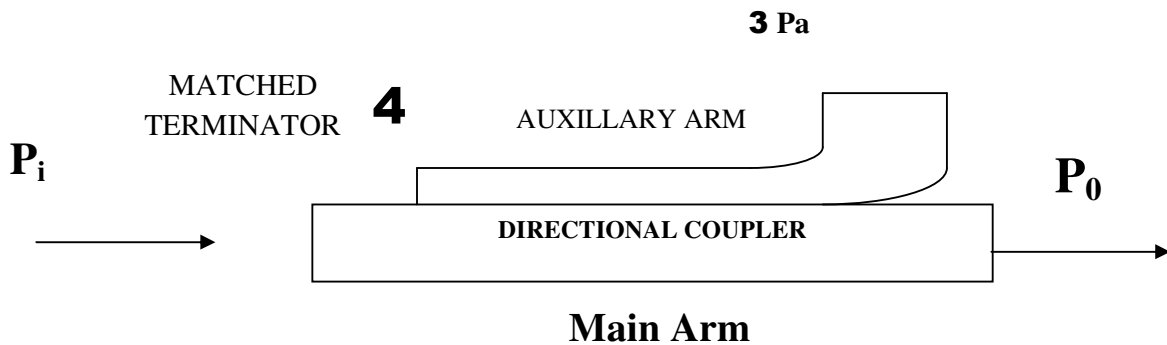

### PROCEDURE

1. Connect the components and equipment as shown in fig.
2. Keep the control knob of klystron power supply as below:
  - a. Modulation selection : AM
  - b. Beam voltage knob : Fully anti-clockwise
  - c. Reflector voltage knob : Fully clockwise
  - d. Selector switch : Beam voltage
3. Keep the AM modulation control knob of amplitude & frequency at mid position.
4. Switch on the klystron power supply.
5. Now vary the Beam voltage knob to 295V or 200v and a reflection voltage of 150 V . Next change the selector knob to Beam Current. Observe the BEAM CURRENT. [The beam current should not be more than 30 m amps].
6. Now observe the square wave form in CRO by varying either reflector voltage or adjusting the amplitude knob of AM.
7. Connect the slotted section output to detector mount, now measure the input Power ( $P_1$ ).
8. Disconnect to setup as shown in fig 2.
9. Now connect the slotted section output to directional coupler input (port1), connect the detector mount at port2, Terminate the port4 with matched termination.
10. Now measure the Power ( $P_2$ ) at port 2. Then remove detector mount from port2 and connect to port 4 terminate port 2 with matched termination
11. Now measure the power ( $P_3$ ) at port 3.
12. Now remove the directional coupler from slotted section. And connect the slotted section output to directional coupler port2, connect the detector mount at Port1, terminate the port4, with matched termination
13. Now measure the power ( $P_4$ ) at port 1 and tabulate readings.

**TABULATION:**

**Beam Voltage = -- V**  
**Beam current = -- ma**  
**Replier Voltage =**

S.No	Power of (P1)	Power of (P2)	Power of (P3)	Power of (P4)	Coupling Loss	Transmission Loss	Directivity

Coupling Factor(C)  $C = 10 \log_{10} \left( \frac{P_1}{P_{3f}} \right), dB$

$$C = 20 \log_{10} \left( \frac{V_1}{V_{3f}} \right), dB$$

$P_1$  = input power to the primary guide

$P_{3f}$  = output power at auxiliary guide

Directivity (D)  $D = 10 \log_{10} \left( \frac{P_{3f}}{P_{3r}} \right), dB$

$$D = 20 \log_{10} \left( \frac{V_{3f}}{V_{3r}} \right), dB$$

$P_{3f}$  = power of the auxiliary arm due to power in forward direction

$P_{3r}$  = power of the auxiliary arm due to power in reverse direction

Transmission loss  $T = 10 \log_{10} \left( \frac{P_1}{P_2} \right), dB$

$$T = 20 \log_{10} \left( \frac{V_1}{V_2} \right), dB$$

Isolation loss  $= 10 \log_{10} \left( \frac{P_4}{P_1} \right), dB$

$$= 20 \log_{10} \left( \frac{V_4}{V_1} \right), dB$$

Tabulate the readings and calculate the s-parameters from :

$$S_{21} = V_2/V_1 ; S_{31} = V_3/V_1 ; S_{41} = V_4/V_1$$

**RESULT**

Thus the characteristic of directional coupler was studied and the following parameters are found below:

$S_{21} =$  ;  $S_{31} =$  ;  $S_{41} =$

Coupling Factor(C) =

Directivity (D) =

Transmission loss =



**EX.NO:14**

**DATE:**

**S - PARAMETER MEASUREMENT OF ISOLATOR AND CIRCULATOR**

**AIM**

To study the S - parameter measurement of isolator and circulator.

**EQUIPMENTS REQUIRED**

1. Microwave source (klystron power supply)
2. Klystron Mount
3. Isolator
4. Variable Attenuator
5. Frequency meter
6. Circulator / Isolator
7. Power Detector
8. Matched termination ----- 1 No

**EXPERIMENTAL SET UP FOR ISOLATOR**

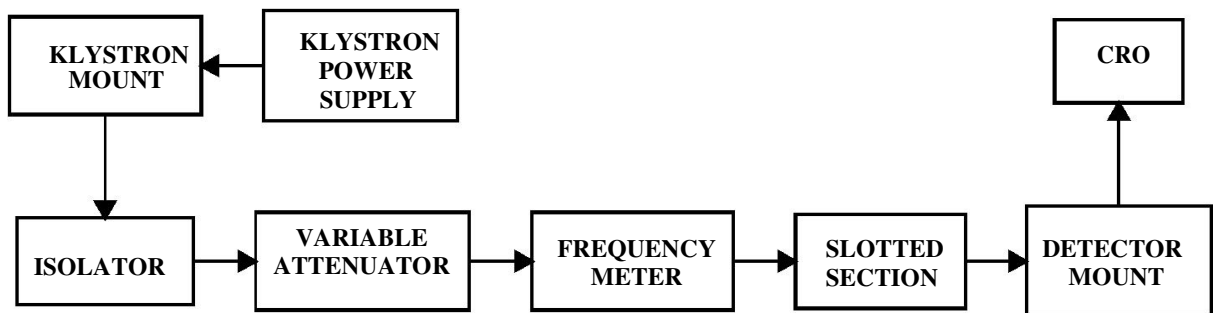

**PROCEDURE**

1. Connect the components and equipment as shown in fig. 2
2. Keep the control knob of klystron power supply as below:
 

Modulation selection	: AM
Beam voltage knob	: Fully anti-clockwise
Reflector voltage knob	: Fully clockwise
Selector switch	: Beam voltage
3. Keep the AM modulation control knob of amplitude & frequency at mid position.
4. Switch on the klystron power supply.
5. Now vary the Beam voltage knob to 295V. Next change the selector knob to Beam Current. Observe the BEAM CURRENT. [The beam current should not be more than 30 m amps].
6. Now change the selector switch to Reflector voltage position.
7. Now decrease the Reflector voltage to minimum position.
8. Now observe the square wave form in CRO by varying either reflector voltage or adjusting the amplitude knob of AM.
9. Connect the slotted section output to detector mount measure the power (or) voltage (A1) using CRO (or) power meter.
10. Now remove the detector mount from slotted section and connect the Isolator Port 1n to slotted section output , connect the detector mount in Port 2, now measure the power (or) voltage (A12) using CRO (or) power meter.
11. Now remove the isolator from slotted section and connect the isolator Port 2 to the slotted section output, connect the detector power (or) voltage (A21) using CRO (or) power meter.

**TABULATION**

SL.NO	PORT 1	PORT 2

Insertion Loss (dB) = A1-A12 dB

Isolation dB = A1-A21dB

**FORMULA**

- The S – matrix of 3 – port circulator is

$$S = \begin{bmatrix} 0 & 0 & 1 \\ 1 & 0 & 0 \\ 0 & 1 & 0 \end{bmatrix}$$

Where

$$S_{11} = S_{22} = S_{33} = 0$$

$$S_{12} = S_{23} = S_{31} = 0$$

$$S_{21} = 20 \log \left( \frac{V_2}{V_1} \right)$$

$$S_{13} = 20 \log \left( \frac{V_1}{V_3} \right)$$

$$\text{Insertion loss} = 10 \log \left( \frac{P_1}{P_2} \right)$$

$$\text{Isolation} = 10 \log \left( \frac{P_1}{P_3} \right)$$

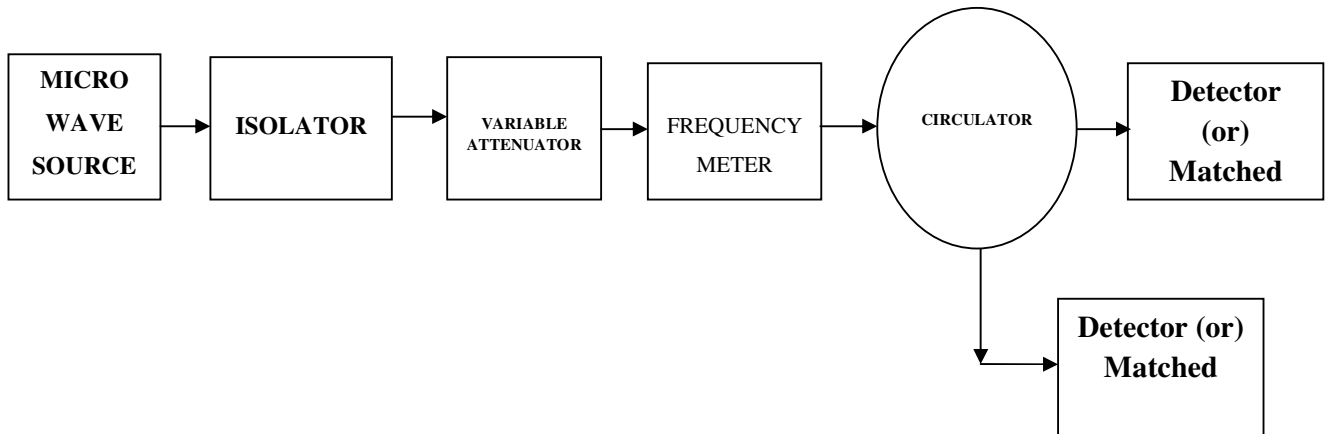
**EXPERIMENTAL SETUP****PROCEDURE**

1. Arrange the bench setup without connecting circulator and measure the input power.
2. Now connect the circulator and note down the output power at port 2 & port 3
3. Substitute the values to estimate the S – matrix of Circulator.

**TABULATION**

SL.NO	PORT 1	PORT 2	PORT 3

**RESULT**

Thus the S - parameter measurement of isolator and circulator has been observed.

**EX.NO:15**

**DATE:**

**S - MATRIX CHARACTERIZATION OF E-PLANE TEE,  
H-PLANE TEE AND MAGIC TEE.**

**AIM**

To determine the isolation, coupling coefficient and input VSWR for E and H plane waveguide Tee and Magic Tee junctions.

**EQUIPMENTS REQUIRED**

1. Klystron power supply,
2. Klystron with mount,
3. isolator,
4. variable attenuator,
5. slotted section,
6. Magic Tee,
7. Matched termination,
8. detector mount,
9. CRO.

**THEORY**

**H Plane Tee**

Fig 1(a) shows the sketch of an H plane tee. It is clear from the sketch that an auxiliary waveguide arm is fastened perpendicular to the narrow wall of a main guide, thus it is a three port device in which axis of the auxiliary or side arm is parallel to the planes of the magnetic field of the main of the main guide and the coupling from the main guide to the branch guide is by means of magnetic fields. Therefore, it is also known as H plane tee.

The perpendicular arm is generally taken as input and other two arms are in shunt to the input and hence it is also called as shunt tee. Because of symmetry of the tee; equivalent circuit of H plane, when power enters the auxiliary arm, and the two main arms 1 and 2 are terminated in identical loads, the power supplied to each load is equal and in phase with one another.

If two signals of equal amplitude and in same phase are fed into two main arms 1 and 2, they will be added together in the side arm. Thus H plane tee is an 'adder'.

**E Plane Tee**

It is clear from the sketch of the E plane tee that an auxiliary waveguide arm is fastened to the broader wall of the main guide. Thus it is also a three port device in which the auxiliary arm axis is parallel to the plane of the electric fields of the main guide, and the coupling from the main guide to the auxiliary guide is by means of electric fields. Therefore, it is also known as E plane tee. It is clear that it causes load connected to its branches to appear in series. So it is often referred to as a series tee.

As indicated in fig, the two main guide arms are symmetrical with respect to the auxiliary guide arm. As such if power is fed from the auxiliary arm, it is equally distributed in the two arms 1 and 2 when they are terminated in equal loads. However as depicted in the field configuration, the power flowing out in arm 1 is 180 out of phase to the one in arm 2. As such its tee is known as 'subtractor' or 'differencer'.

### H-PLANE Tee:

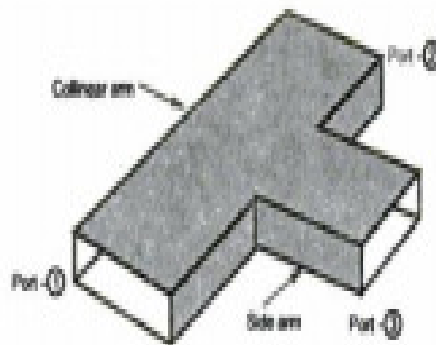

### MAGIC Tee

An interesting type of T junction is the hybrid tee, commonly known as 'magic tee' which is shown in fig. The device as can be seen from fig is a combination of the E arm and H plane tees. Arm3, the H arm forms an H plane tee and arm 4, the E arm, forms an E plane tee in combination with arms 1 and 2. The central lines of the two tees coincide and define the plane of symmetry, that is, if arms 1 and 2 are of equal length, the part of structure on one side of the symmetry plane shown by shaded area is the mirror image of that on the other. Arms 1 and 2 are sometimes called as the side or collinear arms.

### Magic of the MAGIC Tee

The name 'magic Tee' is derived from the manner in which power divides among various arms. If power is fed into arm3, the electric field divides equally between arms 1 and 2 and the fields are in phase. Because of symmetry of the T junction, no net electric field parallel to the narrow dimension of the waveguide is excited in arm 4. Thus no power is coupled in port 4. Reciprocity demands no coupling in port 3 if power is fed in 4.

Another property that results from the symmetry of the junction is, if power is fed in E or H arm, it is equally divided between arms 1 and 2. Further, magic tee being combination of E and H plane tees, if power is fed from arms 1 and 2, it is added in H arm (3) while is subtracted in E arm (4).

A simple E-H tee has disadvantage of not being matched when seen from E and H arms when side arms are terminated in matched loads. The VSWR being  $> 2$  the most commonly used method to reduce VSWR is to introduce discontinuity such as port iris in or near T junction to cancel out reflections occurring there in.

### **E Plane, H Plane Tee Parameter**

#### **Isolation**

The isolation of a T junction is the ratio of power supplied from a matched generator to one of the arms, to the power coupled to a matched detect or in any other arm when the remaining arm is terminated in a matched load.

Isolation between port 1 and 2 is

$$I_{12} = 10 \log_{10} \left( \frac{P_1}{P_2} \right) \text{dB}, I_{12} = 20 \log_{10} \left( \frac{V_1}{V_2} \right) \text{dB},$$

And when matched load and detector are interchanged

$$I_{13} = 10 \log_{10} \left( \frac{P_1}{P_3} \right) \text{dB}, I_{13} = 20 \log_{10} \left( \frac{V_1}{V_3} \right) \text{dB},$$

Similarly

$$I_{31} = 10 \log_{10} \left( \frac{P_3}{P_1} \right) \text{dB}, I_{31} = 20 \log_{10} \left( \frac{V_3}{V_1} \right) \text{dB},$$

And when matched load and detector are interchanged,

$$I_{32} = 10 \log_{10} \left( \frac{P_3}{P_2} \right) \text{dB}, I_{32} = 20 \log_{10} \left( \frac{V_3}{V_2} \right) \text{dB},$$

When arm 2 becomes the input, we will have other two values of isolation,  $I_{21}$  and  $I_{23}$ . Due to reciprocity Property,  $I_{21}$  will be the same as  $I_{12}$ . Therefore, we shall measure only the first four isolation coefficients.

### b) Coupling coefficient

Corresponding to the values of isolation, we can compute The coupling coefficient by the formula

$$C = 10^{-\alpha/20}$$

Where

$\alpha$  is the attenuation in db between the input and detector arm when the third arm is terminated in a matched load. For example, the attenuation measured between arms 1 and 2 is 3 db when arm 3 terminated in matched load, that is, the coupling coefficient between arms 1 and 2,

$$C = 10^{-\alpha/20} = 10^{-3/20} = 0.708dB$$

### c) Input VSWR

There are three values of input VSWR associated with a tee, one for each arm. The VSWR of any arm of a tee is the voltage standing wave ratio existing on a transmission line terminated by that arm of the tee when the other two arms of the tee are terminated in matched loads.

#### Magic Tee Parameter:

The basic properties and associated quantities to be measured for a magic tee are defined as follows:

#### a) Input VSWR

Corresponding to each port of a magic tee as load to the line, there is a value of VSWR. Thus there are four values of VSWR. VSWR is defined as the ratio of maximum voltage to minimum voltage of the standing waves existing on the line when one port of the tee terminates the line while other three ports are terminated in matched loads.

#### b) Isolations

The isolation between E-and H-arms is defined as the ratio of the power supplied by the matched generator connected to E-arms (port-4), to the power detected in H- arm (port-3) by a matched detector when collinear arms (1&2) are terminated in matched loads. It is expressed in db.

$$I_{34} = 10 \log_{10} P_4/P_3, I_{34} = 20 \log_{10} (V_4 / V_3)$$

$P_4$  : power incident in port4(E-arm)

$P_3$  : power detected in port3 (H-arm)

Similarly isolation between other ports may also be defined and measured.

#### c) Coupling Coefficient:

The voltage coupling coefficient from arm I to arm j is defined as  $C_{ij} = 10^{-\alpha/20}$



**EXPERIMENTAL SETUP H-PLANE TEE:**

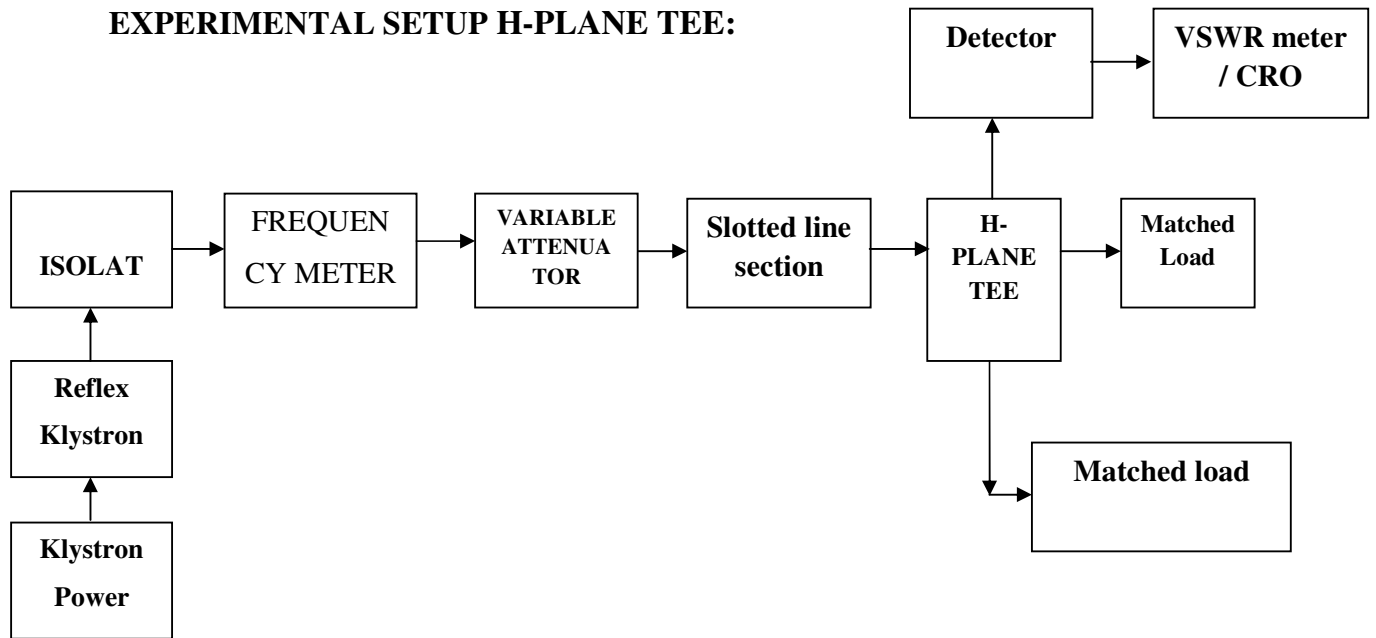

**EXPERIMENTAL SETUP E-PLANE TEE:**

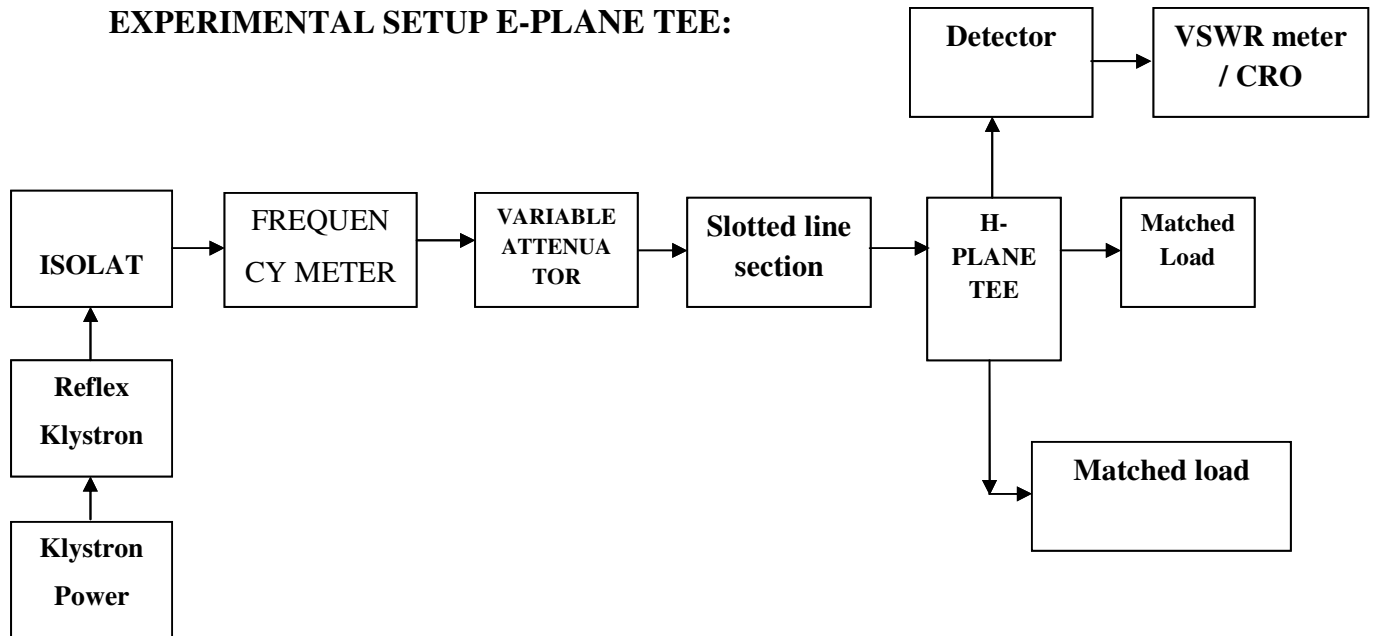

**EXPERIMENTAL SETUP MAGIC TEE:**

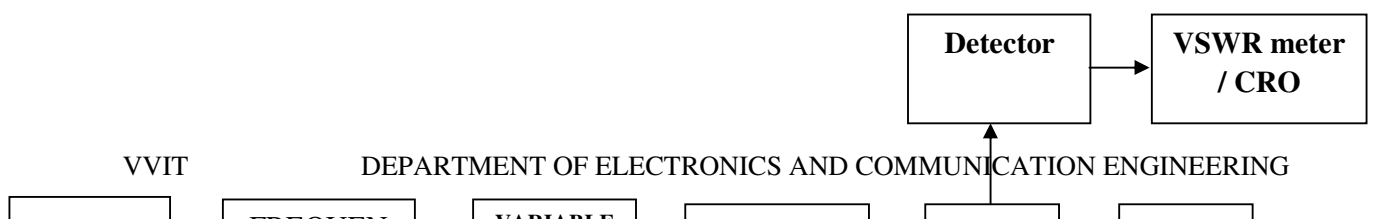

**Procedure:**

1. Setup the components as shown, with port 1 of tee(E-plane/H-plane/Magic Tee) towards slotted line and matched termination to other ports.
2. Energize the microwave source and set mode 3.
3. Calculate VSWR by measuring  $V_{max}$  and  $V_{min}$  by adjusting the slotted line carriage.
4. Similarly connect other arms and calculated VSWR as above.

**Isolation and Coupling Coefficient**

1. Remove the slotted line and Magic Tee/ E/H Tee and connect the detector mount.
2. Energize the microwave source and set mode 3.
3. Note down the input voltage as  $V_i$ (mv) (should not alter the setting)
4. Now connect the magic tee/E-Plane/H-Plane Tee.
5. Determine the corresponding voltages  $V_j$ (mv) for each pair of ports by connecting one

port to the source and measuring the output at other port while the remaining ports are connected to matched termination. Determine the isolation and coupling coefficients for the given Tee

**E-Plane and H – Plane  
INPUT VSWR**

SL.NO	Nature of Tee	Load	$V_{max}$ (mv)	$V_{min}$ (mv)	VSWR
-------	---------------	------	----------------	----------------	------

1	E – Plane	1			
		2			
		3			
2	H – Plane	1			
		2			
		3			

**ISOLATION AND COUPLING COEFFICIENTS**

Generator to port i

Detector mount to port j (V<sub>j</sub>)

All other ports terminated using matched termination  $I_{ij} = 20 \log (V_i / V_j)$

$$C_{ij} = 10^{-I_{ij}/20}$$

Where  $\alpha$  is the attenuation in db

when I is the input and j the output arm.

Thus  $\alpha(\text{db}) = 10 \log P_i / P_j$

where P<sub>i</sub> is the power delivered to I arm by a matched generator and P<sub>j</sub> is the power detected by a matched detector in arm j.

In the case of magic tee, there are 12 coupling constants, one for each of the arms as an input to each of the other three arms as an output. However, if we have a perfectly matched detector and generator,  $C_{ij} = C_{ji}$  and also the reciprocity desires  $C_{12} = C_{21}$ ,  $C_{32} = C_{31}$  and  $C_{41} = C_{42}$

**.ISOLATION AND COUPLING COEFFICIENTS**

SL.NO	Nature of Tee	Voltage (mv)		Isolation (Iij) dB	Coupling Coefficient $C_{ij} = 10^{Iij/20}$				
		I/P	O/P						
	E-Plane	1 <sup>st</sup> arm	2 <sup>nd</sup> arm		$C_{12} =$				
			3 <sup>rd</sup> arm			$C_{13} =$			
			3 <sup>rd</sup> arm		2 <sup>nd</sup> = 52			$C_{32} =$	
					1 <sup>st</sup> arm = 48	$C_{31} =$			
				H = Plane	1 <sup>st</sup> arm			2 <sup>nd</sup> arm	
						3 <sup>rd</sup> arm		$C_{13}$	
			3 <sup>rd</sup> arm			2 <sup>nd</sup>			
						1 <sup>st</sup> arm		$C_{31}$	

**MAGIC TEE:**

SL.NO	Load	$V_{max}(mv)$	$V_{min}(mv)$	VSWR
1	PORT 1			
2	PORT 2			
3	PORT 3			
4	PORT 4			

**OBSERVATIONS:**

Beam voltage =

Repeller voltage =

**Input power at port 3 =**

Power at port 4 =

Power at port 1 =

Power at port 2 =

**Input power at port 4 =**

Power at port 3 =

Power at port 1 =

Power at port 2 =

**Input power at port 1 =**

Power at port 2 =

Power at port 3 =

Power at port 4 =

**Input power at port 2 =**

Power at port 1 =

Power at port 3 =

Power at port 4 =

**Result :**

Thus the isolation, coupling coefficient and input VSWR for E, H plane waveguide Tee and Magic Tee junctions are measured and also the S parameters are determined.

**EX.NO:16**

**DATE:**

**RADIATION PATTERN OF HORN ANTENNA**

**AIM:**

To measure the polar pattern and gain of the waveguide horn antenna.

**EQUIPMENTS REQUIRED**

1. Klystron power supply with mount.
2. Isolator.
3. Variable attenuator.
4. Frequency meter.
5. Horn antenna.
6. Detector mounts.
7. CRO

**PROCEDURE:**

**ANTENNA RADIATION PATTERN**

1. Set up the equipments as shown in figure keep the axis of both the antenna in same line of sight.
2. Energize the Klystron Mount for maximum output at desired frequency with the square wave modulation.
3. Tune the receiving horn to the left in 2 or 5 steps up to 0-5 and note corresponding output voltage.
4. Repeat the above step but this time turn the receiving horn to the right and note down the readings.
5. Plot the relative power pattern its output vs angle.
6. From diagram determine 3 db width of the horn antenna.

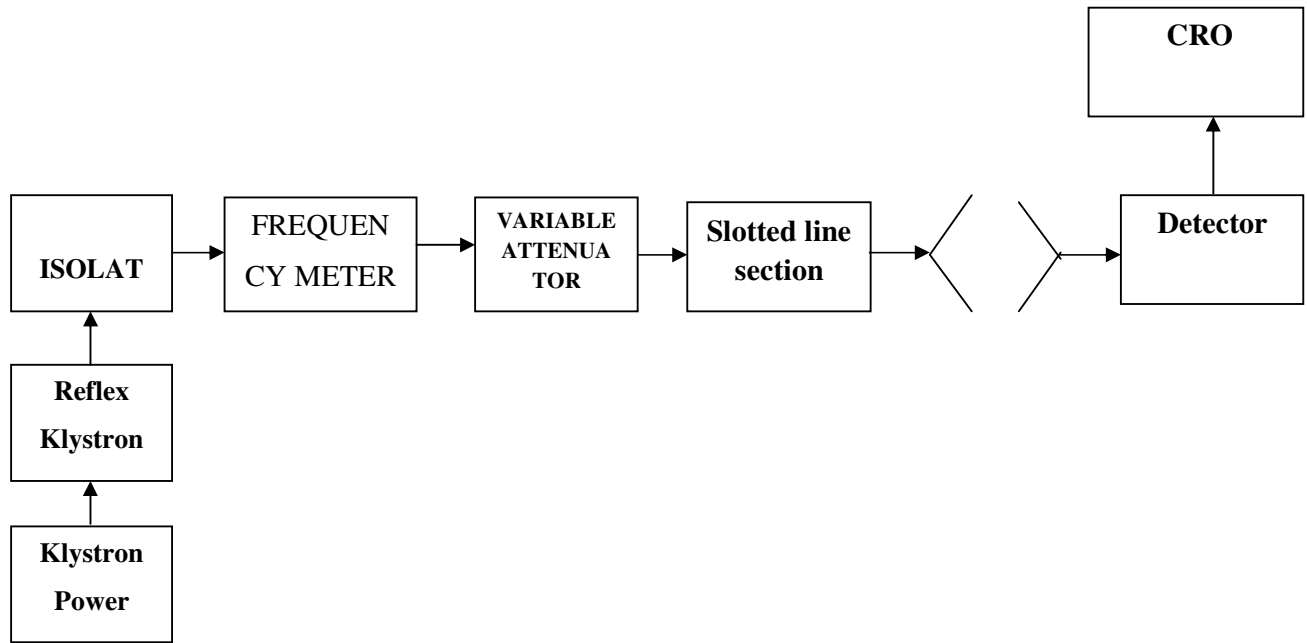

TABULATION

Sl.No	Angle (Degree)	Output Voltage (Volts)	GAIN = 20 log(Vo/Vin) dB

$V_{in} =$

Volts

**RESULT:**

Thus the radiation pattern of an antenna was drawn.